

# Electric Service Guide

[www.pnm.com/esg](http://www.pnm.com/esg)



Talk to us.



# Table of Contents

**Introduction and  
General  
Information  
Page 1**

<b>Introduction and General Information</b> .....	1
Foreword.....	1
Introduction.....	1
Electric Inspection Permits.....	4
Temporary Electric Service.....	5
Underground Utilities Locating Service “Call Before You Dig”.....	6
Power Disturbances.....	7
PNM Service Territories.....	10
Phone Numbers and Addresses.....	11

**Single Family  
Homes:  
Electric Service  
Requirements  
Page 13**

<b>Steps for You to Follow to Receive Electric Service for Your Home</b> .....	14
1. Plan for Your Electric Service.....	14
2. Submit Your Specifications to Us.....	15
3. Develop the Line Extension Agreement.....	16
4. Make Payment for Electric Facilities.....	17
5. Construct Facilities to Receive Permanent Power.....	18

**Multiple Leased  
Residential Units  
Electric Service  
Requirements  
Page 22**

<b>Steps to Follow to Receive Electric Service for Your Multiple Leased Residential Units</b> .....	23
1. Plan for Your Electric Service.....	23
2. Submit Your Specifications to Us.....	24
3. Develop Line Extension Agreement.....	25
4. Make Payment for Electric Facilities.....	27
5. Construct Facilities to Receive Permanent Power.....	27

**Residential  
Subdivisions:  
Electric Service  
Requirements  
Page 33**

<b>Steps to Follow to Provide Electric Service to Your Subdivision</b> .....	34
1. Plan for Electric Service.....	34
2. Submit Your Specifications to Us.....	35
3. Develop Line Extension Agreement.....	36
4. Make Payment for Electric Facilities.....	38
5. Develop Your Subdivision.....	38

**Single  
Businesses:  
Electric Service  
Requirements  
Page 40**

<b>Steps to Follow to Receive Electric Service for you Businesses</b> .....	41
1. Plan for Your Electric Service.....	41
2. Submit Your Specifications to Us.....	43
3. Develop Line Extension Agreement.....	45
4. Make Payment for Electric Facilities.....	46
5. Construct Facilities to Receive Permanent Power.....	46

**Commercial/  
Industrial  
Subdivision:  
Electric Service  
Requirements  
Page 53**

<b>Steps to Follow to Provide Electric Service to Your Commercial and Industrial Subdivision</b> .....	55
1. Plan for Electric Service.....	55
2. Submit Your Specifications to Us.....	56
3. Develop Line Extension Agreement.....	57
4. Make Payment for Electric Facilities.....	58
5. Develop Your Commercial/Industrial Subdivision.....	58

**Policies  
Page 59**

<b>Line Clearances from Buildings, Signs and Other Structures</b> .....	60
<b>Access to PNM Equipment</b> .....	61
<b>Customer Generation System</b> .....	62
<b>Preface to Electric Line Extension Policy</b> .....	63
<b>Procedures for Customer-Built Electric Line Extensions</b> .....	64
<b>Rule 15: Electric Line Extension Policy (Effective 12-15-2013)</b> .....	65
<b>Rule 15: Appendix 1: Customer Built System Requirements (12-15-2013)</b> .....	69
<b>Rule 17: Metering (Effective 12-15-2013)</b> .....	72
<b>Rule 18: Service Connections (Effective 12-15-2013)</b> .....	74
<b>Trenching Policy</b> .....	77

**Customer-Owned Generating System:  
Interconnection and REC Purchase Programs**..... 78

1. One - Line Diagram Example Grid -Tied System..... 79
2. One - Line Diagram Example Line - Side Tap..... 80
3. One - Line Diagram Example Battery Backup..... 81
4. Three - Line Diagram Example Grid-Tied System..... 82
5. Site Map (Figure 1)..... 83
6. One - Line, Site Map and Placard Requirements (Figure 2)..... 84
7. One - Line, Site Map and Placard Requirements (Figure 3)..... 85
8. One - Line, Site Map and Placard Requirements (Figure 4)..... 86
9. One - Line, Site Map and Placard Requirements (Figure 5)..... 87

## Construction Drawings

<b>Name of Drawing</b>	<b>Drawing Number</b>
Tree and Brush Trimming.....	ES-1.0
Maximum Available Fault Currents.....	DM-4-11.0
Attachment of Service to Riser.....	DS-4-3.0
Attachment of Service to Building.....	DS-4-4.0
Minimum Point of Attachment Height for Service Drop Cables.....	DS-4-4.5
Underground Service Entrance System.....	DS-4-5.0
Permanent Service Entrance (Can be used for Temporary Service).....	DS-4-5.5
Remote Temporary Meter Pole.....	DS-4-5.7
120/240V Underground Service Pole.....	DS-4-6.0
Single-Phase Customer Owned Riser on Customer Owned Residential Service Pole.....	DS-4-7.0
Overhead Permanent/Temporary Single-Phase or Temporary Three-Phase Service Pole.....	DS-4-8.0
200A Temporary Three-Phase Pedestal Metering.....	DS-4-8.5
Underground Residential Customer-Owned Service.....	DS-4-9.0
Underground Residential Customer-Owned Service on PNM Owned Secondary Pole.....	DS-4-9.3
Underground Commercial Customer-Owned Service.....	DS-4-9.5
120/240V Underground Single-Phase Commercial Pedestal-Metering.....	DS-4-10.0
Single-Phase Padmounted Transformer Commercial Application.....	DS-7-14.0
Three-Phase Padmounted Transformer Customer Installed.....	DS-7-15.0
Three-Phase Padmounted Primary Meter and Switchgear Customer Installed.....	DS-7-15.1
Three-Phase Padmounted Transformer from Padmounted Switchgear.....	DS-7-15.2
Three-Phase Padmounted Primary Meter and Padmounted Switchgear.....	DS-7-15.3
Single-Phase Padmounted Transformer from Padmounted Switchgear.....	DS-7-15.4

50-167 kVA Type I Transformer Single-Phase Box Pad Southern Division ONLY	DS-7-15.9
25-167 kVA Residential Single-Phase Box Pad	DS-7-16.0 Page 1
25-167 kVA Residential Single-Phase Box Pad	DS-7-16.0 Page 2
25-167 kVA Commercial Single-Phase Box Pad	DS-7-16.1
75-500 kVA Three-Phase Radial Fed Transformer Pad	DS-7-16.5
750-1500 kVA Three-Phase Radial Fed Transformer Pad	DS-7-16.6
75-500 kVA Three-Phase Loop Fed Transformer Pad	DS-7-16.7
750-1500 kVA Three-Phase Loop Fed Transformer Pad	DS-7-16.7.1
Guard Post	DS-7-16.10
Minimum Working Space and Fire Safety Requirements for Transformers	DS-7-16.12
Working Space and Fire Safety Requirement Supplement	DS-7-17.0
75-150 kVA Radial Fed Transformer and Metering Enclosure Pad	DS-7-17.5
75-750 kVA Loop Fed Transformer and Metering Enclosure Pad	DS-7-17.6
300-500 kVA Radial Fed Transformer and Metering Enclosure Pad	DS-7-17.8
750-1500 kVA Radial Fed Transformer and Metering Enclosure Pad	DS-7-17.9
Working Space Required for Padmounted Switchgear	DS-9-17.0
200 Amp Tangent Riser Three-Phase 1/0, Three 2" Conduits	DS-10-6.4.5
Trench Details	DS-10-8.0 Page 2
Trench Details	DS-10-8.0 Page 3

Trench Details.....	DS-10-8.0 Page 4
Trench Details.....	DS-10-8.0 Page 5
Trench Details.....	DS-10-8.0 Page 6
Trench Details.....	DS-10-8.0 Page 7
Trench Details.....	DS-10-8.0 Page 8
Trench Details (Rocky Areas).....	DS-10-8.0 Page 9
Trench Details (Rocky Areas).....	DS-10-8.0 Page 10
Trench Details.....	DS-10-8.0 Page 11
Secondary Pedestal.....	DS-10-12.0 Page 1
Secondary Pedestal Conduit Orientation.....	DS-10-12.0 Page 2
Clearances from Buildings and Other Structures.....	DS-13-2.0 Page 1
Clearances from Buildings and Other Structures.....	DS-13-2.0 Page 2
Clearances from Buildings and Other Structures.....	DS-13-2.0 Page 3
Clearances from Lighting and Traffic Light Supports and Structures of a Second Line.....	DS-13-2.3
Vertical Clearances above Ground, Roadway, Rail or Water Surfaces.....	DS-13-2.5 Page 1
Vertical Clearances above Ground, Roadway, Rail or Water Surfaces.....	DS-13-2.5 Page 2
Vertical Clearances above Ground, Roadway, Rail or Water Surfaces.....	DS-13-2.5 Page 3
Swimming Pool Clearances-Overhead.....	DS-13-6.0
Swimming Pool Clearances-Underground.....	DS-13-7.0

Service for Hazardous Areas.....	DS-13-8.0
Clearances for Gasoline and LPG Filling Station.....	DS-13-8.5
Ground Assembly.....	DS-18-20.0 Page 1
Ground Assembly.....	DS-18-20.0 Page 2
Universal Support Brackets.....	DS-18-22.0

### **Meter Drawings**

<b><u>Name of Drawing</u></b>	<b><u>Drawing Number</u></b>
PNM Approved Meter Equipment	
Meter Socket Ring.....	MS-2-1.0
120/240V 125/200A Permanent Overhead and Underground Single-Phase Meter Socket.....	MS-2-2.0
120/240V 100-125A Single-Phase Meter Socket Customer Overhead Services.....	MS-2-2.3
240V 200A Single-Phase Meter Socket Customer Overhead Services.....	MS-2-2.5
120/240V 125/200A Commercial Single-Phase Multi-Meter Socket with Bypass.....	MS-2-3.0
120/240V 125/200A Residential Single-Phase Multi-Meter Socket.....	MS-2-4.0
120/240V 200A Single-Phase Meter Socket with Bypass.....	MS-2-5.0
120/208 Wye or 120/240 Delta 200A Three-Phase Four-Wire Wye or Delta Meter Socket with Bypass.....	MS-2-6.0
200A Three-Phase Four-Wire Wye 277/480V Wye Meter Socket with Bypass.....	MS-2-6.3
Single-Phase Six-Terminal CT Meter Socket.....	MS-2-6.5
Three-Phase Thirteen-Terminal CT Meter Socket.....	MS-2-7.0
Ringless Trans Socket.....	MS-2-8.0
240V 200A Single-Phase Combo Meter Socket.....	MS-2-9.0
320A Meter Socket with Bypass.....	MS-2-10.0
Double Window Three-Phase Instrument Transformer and Meter Enclosure.....	MS-3-2.0
Over 200A 240V Single-Phase Meter.....	MS-3-7.0
Over 200A Three-Phase Overhead Meter Options.....	MS-3-7.5
Over 200A Three-Phase Underground Meter Options.....	MS-3-8.0



Over 200A Three-Phase Underground Meter Options (Maintenance or Special Metering Situation ONLY).....	MS-3-8.5
277/480V Instrument Transformer and Meter Enclosure for Meter Network.....	MS-3-9.0
Single-Phase Bushing CT Meter Installation.....	MS-3-9.5
Three-Phase Bushing CT Meter Installation.....	MS-3-10.0
120/208-277/480V CT Meter Enclosure.....	MS-3-11.0
Optional Equipment to Provide Meter Data for Customer Use.....	MS-3-12.0
120/208-277/480V Transformer and Meter Enclosure Using Trough.....	MS-3-14.0
120/208-277/480V Enclosure Pad.....	MS-3-16.0
7200/12470V CT and PT Meter Enclosure.....	MS-3-17.0
7200/12470V Primary Meter Enclosure.....	MS-3-18.0
7200/12470V CT and PT Meter Enclosure Mounts.....	MS-3-20.0
7200/12470V CT and PT Enclosure Pad.....	MS-3-21.0
120/240V Single-Phase Four-Terminal Modular Meter and Equipment.....	MS-4-1.0
120/208V Five-Terminal Modular Meter and Equipment.....	MS-4-2.0
120/208-277/480V 200A Three-Phase Four-Wire Multiple Meter.....	MS-4-3.0
120/208-277/480V Three-Phase Four-Wire Multiple Meter.....	MS-4-4.0
Rain Tight Housing for Switchgear and Meter.....	MS-4-5.0
Switchgear Meters with Padmount Transformer.....	MS-4-7.0
Switchgear Seven-Jaw Socket Meter.....	MS-4-8.0
Cradle Mount CT Switchgear Metering.....	MS-4-9.0
120/208 or 277/480V Switchgear Metering.....	MS-4-11.0
120/240V 125-320A Pedestal Meter.....	MS-5-2.0
Permanent Single-Phase or Three-Phase Pedestal Meter.....	MS-5-3.0
Three-Phase or Single-Phase Overhead or Underground Field Built Structure.....	MS-5-4.0
Over 400A Permanent Three-Phase Pedestal Meter.....	MS-5-5.0
240V Single-Phase Commercial Pedestal Meter.....	MS-5-6.0
Underground or Overhead Working Space for Electric Meter.....	MS-7-1.0

Underground or Overhead Working Space for REC Meter.....	MS-7-1.5
Working Space Required for Meter Enclosure.....	MS-7-2.0
REC Meter Base Standard 120/240V Meter Base–Neutral NOT Bonded.....	MS-8-1.0
Third Party Meter with REC Meter Base Standard 120V Meter Base.....	MS-8-1.1
Third Party Meter with REC Meter Base Standard 240V Meter Base-Neutral NOT Bonded.....	MS-8-1.2
REC Meter Base Standard 240V Meter Base without Neutral.....	MS-8-1.5
120/240 100–150A Single–Phase REC Meter Socket for Renewable Systems Less Than 10 kW.....	MS-8-2.0
277/480V, 120/208V Four-Wire Ground Wye 1 Inverter, 3 Outputs without Neutral.....	MS-8-3.0
277/480V, 120/208V Four-Wire Ground Wye 1 Inverter, 3 Outputs with Neutral.....	MS-8-3.3
277/480V, 120/208V Four-Wire Ground Wye 3 Inverters, 3 Outputs with Neutral.....	MS-8-3.7
7200/12470V Primary REC Meter Enclosure.....	MS-8-5.0
Over 200A Three-Phase REC Meter Options.....	MS-8-6.0



# Introduction and General Information

The Electric Service Guide in general is for PNM Service Territories (See page 10). Check with your new service representative to determine which steps are appropriate for your situation.

## Foreword

**Let us know if you have any suggested improvements for this book.**

Welcome to the Electric Service Guide. Please read this section for an explanation of and an introduction to the purpose and use of the Electric Service Guide. This section also contains important information on permits, the New Mexico One Call System, and power disturbances. Should you have suggestions for improvements or solutions to problems with this guide, forward comments to [DistributionStandards@pnm.com](mailto:DistributionStandards@pnm.com).

## Introduction

**This book will let you know the steps to follow to receive electric service.**

We designed this book to provide you, our Customers, with the most complete, current, and accurate information available to help you plan for electric service in our service area. This guide is derived from the Rules and Regulations covering electric service approved by the New Mexico Public Regulation Commission. Should any statement or provision in this publication seem to conflict with the Rules and Regulations, the Rules and Regulations will prevail.

- The Electric Service Guide is a tool for you to use to plan and build your project.
- The Electric Service Guide can save you time and money.

**Copy of the ESG can be viewed at [www.pnm.com/esg](http://www.pnm.com/esg)**

The ESG can be viewed at [www.pnm.com/esg](http://www.pnm.com/esg). Questions on information contained in this book should be directed to your local PNM office. Electric Service Guide provides guidance to electrical contractors, architects, consulting engineers, developers, home-builders, and land planners.

**The procedures in this book enable a complex and regulated process to work for the many people involved.**

The following procedures and requirements are necessary because they provide a structure that allows a complex process to be completed in a predictable and efficient fashion. We realize that any successful development requires cooperation and scheduling among many entities, which could include contractors, utilities, municipalities, banks, and others. Therefore, we provide this document to

- promote mutual planning and scheduling
- promote fair and consistent treatment for you and your contractors
- ensure compliance with the requirements of the Public Regulatory Commission
- coordinate with the requirements of local government inspection and permitting agencies regarding enforcement of the National Electrical Code (NEC), and the National Electrical Safety Code (NESC)
- ensure compliance with all applicable environmental laws

Our process to provide you with electricity is governed by several policies, including the Line Extension Policy that are approved and monitored by the Public Regulatory Commission. These policies are established to ensure that all customers, including those desiring line extensions as well as existing rate payers, are treated fairly and consistently. The complete text of these policies can be obtained from your new service representative. Most of these policies are included in summary form in the section of this document on "Policies" page 59.

**The Electric Service Guide provides guidance to our Customers for most situations but it cannot address all circumstances. The general guidance provided by this book cannot take precedence over your specific requirements, company policies, Public Regulatory Commission Rules and Orders, and the contracts that are developed to serve your needs. Please be sure to discuss your requirements with a new service representative.**

A brief explanation of the contents of each chapter in the book may be found below.

**This chapter provides an overview of the contents of this book.**

### **How to Use the Electric Service Guide**

This chapter of the book outlines the structure and use of this book. You will find chapters of the book that are customized to specific types of developments, ranging in size from single homes to commercial/industrial subdivisions. General contractors, electricians, architects, or others who may perform work for many different types of residential and business structures will find useful information that applies to all types of construction. Also, general information is provided in this section regarding

- electric permits
- power line safety
- the New Mexico One Call System (CALL BEFORE YOU DIG!)
- important phone numbers and addresses
- power disturbances

Each of these chapters has been customized for the requirements for specific types of customers.

There are five chapters devoted to our major customer classifications. These five chapters are:

### **Single Family Homes, Electric Service Requirements**

This chapter focuses on the single family home.

### **Multiple Leased Residential Units, Electric Service Requirements**

Only apartments and leased mobile home parks with individually metered units are explained in this chapter. Master metered apartments are considered to be a single business.

### **Residential Subdivisions, Electric Service Requirements**

Developers building residential subdivisions should refer to this chapter. This chapter focuses on providing electricity to lots, and does not include service to individual homes.

### **Single Businesses, Electric Service Requirements**

This chapter focuses on single commercial businesses. Master metered apartments, and customers desiring primary metered service should use this chapter.

### **Commercial/Industrial Subdivisions, Electric Service Requirements**

This chapter is for developers who want to provide an electric backbone system in a Commercial/Industrial Subdivision. Service to the future businesses within the subdivision will be handled as Single Businesses, above.

Customers should look to the appropriate chapter to determine the steps they need to follow to obtain electric service. Each of the above chapters contains information regarding

- procedures
- technical requirements
- drawing references
- policy summaries (what you need to know)

### **Policies**

The chapter on policies contains general summaries of policies that apply to all customer classes. Policies summarized in this chapter include:

- Line Clearances from Buildings, Signs, and Other Structures
- Access into PNM Equipment
- Customer Generation Systems
- Electric Line Extension Policy
- Metering Policy
- Trenching Policy

Policy summaries may be found in the chapter entitled "Policies", page 59.

**Technical drawings are in the back of this book.**

## **Drawings**

The last chapter contains drawings. The drawings are in numerical order. Our drawings are prefixed with "DS" or "DM" for Construction Drawings and "MS" for Meter Drawings followed by numbers, for example DS-4-5.0, DM-4-11.0 and MS-2-4.0. In this book, drawings referenced in the text may be found in that last chapter. Each chapter in Electric Service Requirements identifies drawings that show material or interconnection requirements. Please reference the appropriate drawing as needed.

## **Electric Inspection Permits**

**PNM must receive a release from the jurisdictional electrical inspector's office before service can be connected.**

In order to ensure public safety, all electrical facilities must be permitted and pass electrical inspection by the City, County, or State authority having jurisdiction. PNM can only energize service after receiving a release from the appropriate jurisdictional body(s) indicating the facility requesting service has passed inspection and meets applicable codes.

**Your electrician can acquire your permit.**

The procedure for acquiring an electrical permit is generally the same throughout the state. The Customer can rely on a licensed electrical contractor to acquire and process the permit for service. Please contact a new service representative if you need clarification with permit and inspection procedures. Locations and phone numbers for electrical permit offices are listed on page 12.

**Certain facilities are exempt from state law and permitting requirements in such cases a Statement of Facts is required prior to service being energized.**

The service entrance equipment must also meet PNM standards and specifications. If the electrical facilities do not pass an inspection by the jurisdictional authority and/or an inspection by PNM, the equipment will be tagged notifying the electrician of deficiencies. Once the deficiencies are corrected, your electrician must request re-inspection.

### **We will never energize facilities that we believe are hazardous.**

**Manufactured homes require an additional permit release from the Manufactured housing Division of State of New Mexico.**

In cases that are exempt from state law requiring a permit, such as installations on Native American properties or certain federal facilities, a Statement of Fact must be executed and submitted to PNM by a licensed electrical contractor. The Statement of Fact form may be obtained from your local PNM field office.

If the building is a manufactured home, additional authorization is required before connecting the service from the Manufactured Housing Division (MHD) in the form of a release issued upon successful inspection after obtaining a MHD permit.

Please allow the time indicated below from the date we receive the electrical inspection release(s) until your service is energized:

- 7 working days for temporary service
- 10 working days for overhead service
- 12 working days for underground service

**If you plan to do your own electrical work, be sure to acquire the proper permit.**

If you plan to do the electrical wiring for your home, you need to acquire a Homeowner's Permit from your local inspection authority. You must present them with a complete drawing of the proposed work, and a Recorded Warranty Deed or Real Estate Contract.

# Temporary Electric Service

You or your electrical contractor may need to construct a temporary service to receive construction power. For best results, have this work completed and make certain we have the permits before we begin construction. This will enable us to connect your service at the time we build your line extension.

The following table shows the drawings to reference for the facilities you need to build to receive construction power.

## **Temporary Service Drawing Summary**

Type of Installation	Single-Phase		Three-Phase	
	Overhead	Underground	Overhead	Underground
Customer's service pole	DS-4-8.0	DS-4-6.0	DS-4-8.0	DS-4-8.5
Meter Socket 200 Amps or less	MS-2-2.0	MS-2-2.0	MS-2-6.0	MS-2-6.0

### **What you need to know about temporary electric service:**

- Temporary electric service is power used during the construction.
- If power is not available on site, you must pay our cost to install and remove facilities needed for construction power.
- Additionally, customers must pay a connection charge. These fees will be charged on your first electric bill for temporary service. This cost is not refundable.

**Before we can connect our electric lines to your temporary service, we must receive a permit from the local inspection authority approving the safety of your facilities. Please allow 7 working days for us to connect your service after we receive the permit and all the other conditions are met. Other conditions may include but are not limited to easement and right-of way, execution and completion of a line extension and permits.**

### **What you need to know about temporary electric permits:**

- In order to provide for public safety, all electrical facilities must be inspected and permitted by the City, County, or State having jurisdiction.
- We cannot energize facilities that have not passed inspection by the appropriate jurisdictional authority.
- We will connect your temporary service within 7 working days of the time we receive the permit.
- Your licensed electrical contractor can acquire and process your permit for electric service.

**Utility power lines can be hazardous! Maintain safe work clearances from power lines. See page 6 for more information.**

You must call for identification of underground utilities before you do any digging. New Mexico has a "One Call" system that enables you to call one phone number, and have the location of all underground utilities marked.

OSHA specifies minimum approach distances when working near overhead power lines. Generally an individual or equipment may not come closer than ten feet of overhead lines.

## Upgrades to Existing Services

In general, upgrades to existing services follow the Electric Line Extension Policy. We require a service upgrade application be submitted for all upgrades so that PNM can review the adequacy of our facilities serving the upgraded service. To submit your applications go to [www.PNM.com/erequest](http://www.PNM.com/erequest).

All upgrades require permitting and an electrical inspection release by the City, County, or State authority having jurisdiction before PNM can reconnect the upgraded service. See also the permitting section of this chapter.

Disconnect/reconnect service appointments can be made by calling your local service center, see Phone Numbers and Addresses section of this chapter. Please make these appointments as early as possible to ensure we can meet your scheduling needs.



## Power Line Safety

Contact PNM if you will be within 10 feet of overhead lines during construction.

It is your responsibility to know and comply with federal regulations, NM state laws, and the Public Regulations Commission's Rules concerning safe work practices near power lines. The following explanations should not be regarded as a substitute for the content of the laws, but are meant to highlight some of the major points.

## Overhead Lines

**Caution: Overhead wires and conductors are not insulated for protection from contact.**

**Care must be exercised when working near overhead facilities.**

NM State Construction Industries Division of the Regulation and Licensing Department 14.10-5.8 has adopted the 2012 National Electrical Safety Code. OSHA 1910.333 specifies clearances when working near overhead power lines.

Each year a number of accidents involving contact with overhead power lines occur, often resulting in serious injury or death. In an effort to prevent these types of accidents, laws have been enacted to provide safer working conditions in areas around overhead electric lines.

These laws apply, with few exceptions, to any person or business entity contracting to do work or perform any activity, which may bring an individual or equipment within 10 feet of power lines. If work is to be performed within 10 feet of power lines, the utility shall be contacted well in advance to arrange for safety provisions which may require de-energizing the lines or relocating the lines either temporarily or permanently.

## UNDERGROUND UTILITIES LOCATING SERVICE “CALL BEFORE YOU DIG”

Utilities work together to prevent damage to their underground facilities.

We have always supported programs that provide for the location of underground facilities. These programs are part of a concept that resulted from the passage of a state law. **Liability for damages to underground facilities is the excavator's responsibility unless the utility improperly locates the underground facilities.** We locate our underground facilities when requested by excavators.

Be sure to call NM811 before you dig, the number is simple just dial 811.

In all PNM divisions, this location service has been formalized into a program called New Mexico 811. This program allows an excavator to call one telephone number for all locations, instead of calling each utility individually. Every utility member who participates receives excavation notices. There is a minimum waiting period of two working days to allow all utilities to appropriately identify their underground facilities. When the utilities have located their facilities, the excavator can determine the individual utility location by the color code assigned to that particular utility. Facilities will be identified with stakes or painted markings.

- BLUE – Potable Water
- GREEN – Sewer and Drain Lines
- RED – Electric Power Lines, Cables, Conduit and Lighting Cables
- WHITE – Proposed Excavation, marked by excavator prior to requesting locates.
- YELLOW – Gas, Oil Steam, Petroleum or Gaseous Materials
- ORANGE – Communications (initials designate company), Alarm or Signal Lines, Cables or Conduits
- PINK – Temporary Survey Markings
- PURPLE – Reclaimed Water, Irrigation and Slurry Lines

It is the excavator's responsibility to contact any other utilities which may also have nearby underground facilities and who do not participate in New Mexico 811. Marking of underground utilities are valid only for a period of 10 days. If this period is exceeded, a new request must be made. Once underground facilities have been located, there should not be any mechanical excavation within 18 inches of the spots.

## What you need to know about the New Mexico One Call System.

- The "Call Before You Dig" number in your area is 811.
- 2 working days notice will be needed before you start excavation.
- Marking is guaranteed accurate for 10 days.
- No mechanical digging can be performed within 18 inches of marking.

If the area is not marked "Clear" or "No Underground Facilities" the excavator shall contact the one-call notification system operating in the intended area or the owners or operators of any existing underground facility in and near the excavation area that are not members of the local one-call notification center in order to verify the area as "Clear" or "No Underground Facilities."

### Locating Underground Customer-Owned Facilities

The customer must locate and spot customer-owned facilities such as sewer and water lines on each lot before we install electric lines. Other customer-owned facilities may include the underground electric service line from a PNM pole to a building. New Mexico One Call will not spot customer-owned facilities. We cannot be responsible for damages to any facilities that are not spotted, or spots that are off by more than 12 inches.

**You are responsible for locating your own facilities, so that other utilities may dig in the vicinity.**

## Power Disturbances

**We provide utility grade electricity.**

PNM provides utility grade service in accordance with the American National Standards Institute (ANSI) standard C84.1 which defines acceptable voltage limits for utility service. ANSI standard C84.1 does not address voltage surge levels or surge duration for electric utility systems.

**Our reliability is high, and we are striving to make it higher, but electric disturbances are inevitable.**

PNM maintains a high level of electric reliability. However, short duration disturbances which occur on our power system can affect the operation of sensitive electronic controls and sensitive electronic equipment. PNM's transmission system typically experiences unavoidable disturbances throughout the year. Most do not cause power interruptions, but can cause voltage fluctuations. These disturbances usually last less than one second and are typical in utility electrical systems.

Disturbances also occur on PNM's distribution system which can cause voltage sags, surges, momentary outages, or single-phasing.

**Protect your operation from disturbances if you have special electrical needs.**

If you have sensitive electronic controls or sensitive computer equipment, it is your responsibility to take appropriate actions to prevent these brief power disturbances from affecting your operation or process. **If you have three-phase equipment it is your responsibility to protect against "single-phasing".**

**Use the following check list to aid in improving power quality.**

The following check lists provide recommendations on grounding and power quality. Please review these lists and incorporate appropriate recommendations into your facility.

### **GROUNDING**

- Securely bond neutral to ground at main distribution panel.
- Maintain an earth ground at service entrance.
- Securely bond building steel to the building electrical ground.
- Install grounding electrode to reduce ground resistance. Securely connect grounding conductor to grounding electrode. (The earth grounding system can be quite complex depending on soil types and your needs. An acceptable earth ground resistance is 25 ohms or less).
- Follow all National Electrical Code (NEC) guidelines.

## POWER QUALITY

- Dedicate separate circuits to computers or sensitive equipment.
- Install an equipment grounding wire with dedicated circuits. Do not rely on conduit as a grounding conductor.
- Secure all connections at the distribution panel(s) and outlets.
- Feed non-linear or electrically noisy loads (such as electronic lighting ballasts, motors, air conditioners and copying machines) from a separate panel if they are a significant part of your total load. Voltage transients from these loads can affect sensitive electronic controls or computer equipment.
- Install necessary **uninterruptible power supplies** for systems that depend on 100% power availability.
- Install necessary constant voltage transformers or other filtering devices for equipment requiring additional power conditioning.
- Install necessary equipment for systems that require controlled temperature and humidity.
- Install bypass metering to minimize interruptions due to meter servicing.

## **PNM Service Territories**

- Albuquerque Metro Division
  - Albuquerque Office
    - City of Albuquerque, Bernalillo County, Ambrosia Lake, and Church Rock
    - East Mountain Area
      - Communities of Carnuel, Cedar Crest, Seven Springs, Sandia Park, San Antonio, Sedillo, Cedro, Yrisarri, Escabosa, and incorporated Villages of Tijeras and Chilili
    - Sandoval County Area
      - Town of Bernalillo, City of Rio Rancho, communities of Placitas, Pena Blanca, the Village of Corrales, Pueblos of Sandia, Santa Ana, and San Felipe
    - Valencia County Area
      - Town of Belen, Village of Los Lunas, Village of Bosque Farms, and Pueblo of Isleta
  - Northern Division
    - City of Santa Fe, Santa Fe County, Pueblos of Santa Domingo and Cochiti, Cochiti Lake, Pueblo of Tesuque, Village of Tesuque
    - Las Vegas Area
      - City of Las Vegas
    - Clayton Area
      - Town of Clayton
- Southern Division
  - Deming Office
    - Village of Deming
  - Silver City Office
    - Town of Silver City, City of Bayard, Town of Hurley, Village of Santa Clara, and City of Lordsburg
  - Alamogordo Office
    - City of Alamogordo and Village of Tularosa
  - Ruidoso Office
    - Village of Ruidoso, Village of Ruidoso Downs, and Hollywood

**Phone Numbers  
and Addresses**

## Phone Numbers and Addresses

Location of Your Project	Phone Number	PNM New Service Delivery Office
Alamogordo	575-443-6610	650 Fairgrounds Rd. Alamogordo, NM 88310
Albuquerque Metro, Bernalillo County, East Mountains, Valencia County, Belen, Los Lunas, Sandoval County, Rio Rancho	505-241-3425	4201 Edith Blvd NE Albuquerque, NM 87107
Ruidoso	575-630-5400	1100 A Mechem Dr. Ruidoso, NM 88345
Santa Fe, Las Vegas, Clayton	505-438-6958	4565 State Rd. 14 Santa Fe, NM 87505
Deming	575-956-1451	524 North Gold Deming, NM 88030
Silver City	575-956-1480	3815 N. Swan St. Silver City, NM 88061
Tribal Lands	PNM's nearest office	See PNM Territories, page 10

Speed up the time to process your service requests by submitting them online. You'll save time, be able to track your open requests, and receive email notifications on the status of your request. Convenience is now a click away!

Get started at [www.PNM.com/erequest](http://www.PNM.com/erequest)

New Mexico One-Call "Call Before You Dig"  
Albuquerque Local: 505-260-1990 or 811  
Toll Free: 1-800-321-2537

\*NOTE: Before serving property outside the city limits of Santa Fe, written verification is required from the County of Santa Fe Land Use Administrator that the property is in compliance with Santa Fe County Subdivision Regulation.

## State or City Electric Permits

Inspector	Address	Phone Number
Alamogordo	650 Fairgrounds Rd Alamogordo, NM 88310	505-222-9813 877-243-0979
City of Albuquerque Electrical Section	600 Second St NW Albuquerque, NM 87102	505-924-3311
Bernalillo County Zoning Building and Planning Department	111 Union Square St SE, Suite 100 Albuquerque, NM 87102	505-314-0350
Clayton	State Electric Permits	505-222-9813 877-243-0979
Deming	State Electric Permits	505-222-9813 877-243-0979
New Mexico Construction/Manufactured Housing Division State Electrical Inspector (East Mountain, Sandoval and Valencia County)	5200 Oakland NE Albuquerque, NM 87113	505-222-9813 877-243-0979
Las Vegas	State Electrical Inspector	505-222-9813 877-243-0979
City of Rio Rancho Electrical Inspector	3900 Southern Blvd SE Rio Rancho, NM 87124	505-803-3379
Ruidoso	1100 A Mechem Dr Ruidoso, NM 88345	505-222-9813 877-243-0979
City of Santa Fe Code Enforcement Division	200 Lincoln Avenue Santa Fe, NM 87501	505-955-6646
Electric Bureau, Construction Industries Division Santa Fe	2550 Cerrillos Rd. Santa Fe, NM 87505	505-476-4700
Silver City	3815 N. Swan St. Silver City, NM 88061	505-222-9813 877-243-0979
Tribal Lands	Contact your local tribal authority	





# Single Family Homes: Electric Service Requirements

**We want to work with you to supply your electrical needs.**

This chapter focuses on the requirements for single family residential homeowners. We want to provide residential homeowners and their contractors with the information they need to plan and receive electric service. We want to work with you and assist you, so that this process works smoothly.

**The procedures in this book enable a complex and regulated process to work for the many people involved.**

The following procedures and requirements are necessary because they provide a structure that allows a complex process to be completed in a predictable and efficient manner. We realize that the successful construction of a home requires cooperation and scheduling among contractors, utilities, municipalities, banks and others. Therefore, we provide this document to

- promote mutual planning and scheduling
- promote fair and consistent treatment for you and your contractors
- ensure compliance with the requirements of the Public Regulation Commission
- coordinate with the requirements of local government inspection and permitting agencies regarding enforcement of the National Electrical Code (NEC), and the National Electrical Safety Code (NESC)
- ensure compliance with all applicable environmental laws

Our process to provide you with electricity is governed by several policies that are approved and monitored by the Public Regulation Commission. The complete text of these policies can be obtained from your new service representative. Most of these policies are included in summary form in the chapter of this document on "Policies", page 59. In this chapter, we provide the important policy information that affects the residential homeowner.

All our procedures are developed to be in compliance with PNM Line Extension Policy. This policy is established to ensure that all customers, those desiring line extensions as well as existing rate payers, are treated fairly and consistently.

## **What you need to know about the Line Extension Policy:**

- The Line Extension Policy governs the costs of building line extensions.
- You will need a line extension to provide electricity to your home.
- Your cost for a line extension is our estimated cost to design and build electric facilities to serve your development less any credits to which you are entitled.
- More information on credits can be read further in this section. (See Policies, page 59)

# Steps for You to Follow to Receive Electric Service for Your Home

The following steps tell you how to obtain electric service for your home. You should coordinate your need for construction power with your permanent line extension, and with your financing (if applicable). The following process will enable you to receive electric service. Don't forget to make arrangements for, and to plan service from, other utilities that you want to serve your home (for example, gas, phone, and/or cable television).

**If electricity is currently available to your property this process may be greatly simplified.**

If power is already available on your property, you may not have to complete all of the following steps. **Special consideration should be taken if installing or upgrading to 200 amp or greater service and/or adding a refrigerated air conditioning system.** Check with your new service representative to determine which steps are appropriate for your situation.

## **1. Plan for Your Electric Service**

**Plan the physical layout and schedule of your electric service.**

Just as you must work with architectural plans for the construction of your home, we must develop plans for the power lines that will supply electricity to your home. Give consideration to where you would like the power to be delivered to your home, and the size of your electric service. Standard voltage for residential customers is 120/240 volt single-phase service. Talk to us if you have special voltage requirements.

- How much electricity will your home use?
- Where and when would you like the construction power delivered to your home?
- Where is the appropriate location for the meter?
- When do you plan to occupy your home?
- Do you plan on a home business? If so, consider bypass metering as shown on MS-2-5.0 this will allow PNM meter exchanges without interrupted service.

**Consider how you will pay for your line extension.**

**You may incur cost for the Electric Line Extension.** You need to consider this cost in the financial planning for your new home.

- How much will your electric line extension cost including securing easements?
- What line extension costs will you need to consider while arranging the financing of your home?

### **Special consideration for remodels and additions:**

- Will the existing meters and transformers accommodate additional load, **especially if changing cooling system from evaporative to refrigerated air conditioning?**
- If the existing service is provided from overhead transformers, will there be enough additional loads to require padmount transformers?
- Will the meter location need to change?

**Please be aware that all work requested after normal working hours and on weekends will be billed to the customer requesting this work on a non-refundable basis.**

**If you plan to do your own electrical work, be sure to acquire the proper permit.**

If you plan to do the electrical wiring for your home yourself, you need to acquire a Homeowner's Permit from your local inspection authority. You must present them with a complete drawing of the proposed work, and a Recorded Warranty Deed or Real Estate Contract.

**Any changes to the original design submitted to PNM could result in additional charges.**

## **2. Submit Your Specification to Us**

[www.PNM.com/erequest](http://www.PNM.com/erequest)

**We need your specifications, so that we can design the electric facilities to serve you.**

All new service or upgrade requests require a Service Application be submitted to PNM. This is done through our on-line Electric Service eRequest system at [www.PNM.com/erequest](http://www.PNM.com/erequest). You'll be able to track your open requests and receive email notification on the status of your request. Please submit your request as early as possible.

Electric service to your home can be a very complex process with many variables. Please discuss and coordinate your specifications with us as early as possible and provide us with all the following:

- recorded warranty deed and plat
- legal description and lot location
- house orientation on lot with distances from property lines
- driveway locations
- heated square feet
- type of heating and cooling system
- special electrical requirements
- existing easements on property
- proposed electric meter location
- utility authorization (Santa Fe only)
- service capacity-there are state and local requirements that require the stamp of an electrical engineer for some loads:
  - The state of New Mexico-when service capacity exceeds 100 kVA single-phase or 225 kVA three-phase requires plans, specifications and calculations to be stamped by an electrical engineer licensed to practice in New Mexico.
  - City of Albuquerque and Bernalillo county-when service capacity exceeds 200 amps for single-phase or 50 kVA for three-phase, the electrical design shall be prepared and sealed by a registered professional engineer, licensed to practice in the State of New Mexico.
  - Other cities or counties may have similar requirements. Check with your local inspection agencies. Refer to page 12 for phone numbers and addresses.

### **What you need to know about electric meter locations:**

- Ask your new service representative for a Meter Location Request.
  - If the meter is installed on the side of your home, it must be within 10 feet of the street side of the house, but not behind stem walls, sidewalls, or other encumbrances.
  - Refer to drawing MS-7-1.0 for required working clearances around meters. In communities with dedicated alleys, requirements may differ on your meter locations.
- Consult with your new service representative before final decisions are made on your meter location.**

**Make sure your building is a safe distance from overhead lines.**

The National Electrical Safety Code (NESC) establishes the clearances that must be maintained between power lines and buildings, signs, and other structures. **These clearances must be maintained, regardless of easement boundaries.** When planning your building, be sure these required clearances are maintained (See drawing DS-13-2.0 in the back section of this book).

**We will estimate the cost of the electrical facilities to serve you.**

We will contact you to discuss your new services requirements and related costs. There are three types of service connections that can be designed, depending on your situation. They are

- overhead service from an overhead line
- customer-owned underground service from an overhead line
- underground service from an underground line

The customer will have the option to acquire their own private easements, which need to be verified by PNM at customer's expense. **The customer may request PNM to acquire these easements at the customer's expense, which will be paid in advance and is nonrefundable.** All easements or permits for governmental agencies must be acquired by PNM.

**We will comply with applicable environmental laws. The responsible protection of natural and cultural resources is a part of the cost of a line extension. This process can be lengthy depending on resources affected and land jurisdiction.**

Trenching

See Trenching Policy, page 77

### **3. Develop the Line Extension Agreement**

**The Line Extension Agreement is a contract for the cost of building the facilities for your electric service.**

You will need to discuss your service options with your new service representative. We will let you know your cost for the permanent line extension that will serve you. You must pay our estimated cost to build the line extension, less any credit for which you are eligible. The types of credits available are explained in the following section.

#### **Policies**

**Policy summaries may be found in the chapter entitled "Policies", page 59.**

The chapter on policies contains general summaries of policies that apply to all customer classes. Policies summarized in this chapter include:

- Line Clearances from Buildings, Signs, and Other Structures
- Access into PNM Equipment
- Customer Generation Systems
- Electric Line Extension Policy
- Metering Policy
- Trenching Policy

**When a line extension passes other unserved lots, the lot credit compensates the line extension customer for the service benefits to these lots.**

## What you need to know about Lot Credits

There are several types of lot credits available to compensate the customer for benefits provided to other properties by the line extension.

Lot credits apply only to lots properly filed and recorded in the County Clerk's office. The customer will need to provide copies of this document to PNM in order to get this credit.

The lot credits include:

- \* **\$470** for each lot made ready for a service drop from either overhead or underground lines.
- \* **\$70** for each lot passed by the new underground backbone line, which will require padmount transformers and/or pedestals and/or secondary wire to provide future service.
- \* **\$340** for each lot passed by the new overhead backbone line, which will require pole-mounted transformers and/or secondary wire to provide future service.
- \* **\$130** for each lot made ready for a service drop by a new overhead transformer hung on an existing pole. This credit is in lieu of the \$470 credit mentioned above.

The total credit given will never exceed PNM's bid or the Customer Built Option Cost, whichever is lower.

**If the customer believes the revenue from his project will exceed that identified on the revenue credit tables, he may sign a Revenue Credit Guarantee Agreement to assume responsibility for meeting the higher revenue figure.**

## What you need to know about Revenue Credits

Up-front revenue credits will be determined by PNM.

In order to be eligible for revenue credits, final building plans must be provided to PNM.

**Any lot receiving a revenue credits is not eligible for a lot credit.**

Once defined, the revenue credit is firm. No revenue credit reconciliation will be made later.

A signed Revenue Credit Guarantee Agreement (RCGA) may be required for customers wishing to demonstrate revenue amounts exceeding those normally identified in the company's Revenue Estimation Table. The RCGA requires the customer to generate actual revenues, which meet or exceed the agreed-upon amount within the first 18 months of permanent electric service, or be billed for the difference. For further information on RCGA see your new service representative.

## **4. Make Payment for Electric Facilities**

PNM can schedule construction for the electric facilities we design to serve you once we have received applicable payments and agreements.

## 5. Construct Facilities to Receive Permanent Power

This section provides information about what you need to build to receive electric service. Although this section identifies requirements for most installations, all situations cannot be addressed in a book of this size. Please be sure to reach an agreement with your new service representative about your electric service facilities before you begin construction.

- A. Overhead service from an overhead line,
- B. Customer owned underground service from an overhead line,
- C. Underground service from an underground line.
- D. For installation across street right-of-way see new service representative.

The requirements for each of these situations are listed on the following pages. Go to the section that describes your situation.

### What you need to know about electric permit releases:

- In order to provide for public safety, all electrical facilities must be permitted, inspected and authorization to energize granted by the City, County or State having jurisdiction to PNM.
- We cannot energize facilities that have not been permitted, passed inspection by the appropriate jurisdictional authority and released to PNM for energizing. The service entrance must also meet PNM Standards and specifications.
- We will connect your service within 10-12 working days of the time we receive the permit release and all the other conditions are met. Other conditions may include but are not limited to easement and right-of way, execution and completion of a line extension and permits.
- Your licensed electrical contractor can acquire and process your permit for electric service.

**Utility power lines can be hazardous! Maintain safe work clearances from power lines. See page 6 for more information.**

You must call for identification of underground utilities before you do any digging. New Mexico has a "One Call" system that enables you to call one phone number, and have the location of all underground utilities marked.

OSHA specifies minimum approach distances when working near overhead power lines. Generally an individual or equipment may not come closer than ten feet of overhead lines.

### A. OVERHEAD SERVICE FROM AN OVERHEAD LINE

**This explains what you own, install, and maintain.**

You will furnish and install an appropriate point of attachment. We will install, own, and maintain the service wires up to the point of attachment on your structure. It is your responsibility to install and maintain all other wiring and equipment past the point of attachment, except for the electric meter.

#### You will install.

- service entrance riser and wiring beyond the point of attachment
- meter socket or enclosure

#### We will install.

- service drop
- transformer
- meter(s)

**Requirements for your service riser and connections to your home.**

Type of Installation		Single-Phase
Service entrance riser, service attachment to: (choose the one that fits your installation)	building	DS-4-3.0 or DS-4-4.0
	service pole	DS-4-8.0
meter socket or enclosure: (choose the one that fits your installation)	200 Amp	MS-2-2.0 or MS-2-5.0
	300 Amp	MS-3-7.0
	>300 Amp	MS-3-7.0
	ganged meters	MS-4-1.0

Underground services from overhead lines are explained here.

This explains what you own, install, and maintain.

Requirements for connection to service pole.

**B. CUSTOMER-OWNED UNDERGROUND SERVICE FROM AN OVERHEAD LINE**

The underground service cables and conduit, (extending from the point of service on your premises to the point on our pole where the connection is to be made) will be designed, installed, owned, maintained, and paid for by you. It is your responsibility that your facilities meet the size and depth requirements of the National Electrical Code (NEC). All conduit runs must be unbroken and contain appropriately sized conductor. Contact your new service representative for the placement of the secondary service conduit attached to our distribution pole. The conduit must not interfere with telephone or cable television company attachments. No switches or attachments other than the continuous run of conduit shall be placed on the pole. We will connect your service cable at our pole and install the meter. You or your contractor is responsible for all other connections, easements and wiring.

**You will install.**

- riser at PNM pole including applicable pole ground assembly
- trench and conduit
- service wires
- meter socket or enclosure

**We will install.**

- transformer(s)
- meter(s)
- terminations at PNM pole

The following is the requirement for the connection of your conduit to our pole.

Type of Installation		Single-Phase
Riser <sup>1</sup> at PNM's pole, trench, and conduit <sup>2</sup>		DS-4-9.0 or DS-4-10.0
meter socket or enclosure: (choose the one that fits your installation)	200 Amp	MS-2-2.0 or MS-2-5.0
	300 Amp	MS-3-7.0
	>300 Amp	MS-3-7.0
	pedestal meter	MS-5-2.0 or MS-5-3.0
	ganged meters	MS-4-1.0

NOTES:

- 1-We will specify the quadrant location for the riser on PNM's pole.
- 2-The service wire will be within a continuous unbroken conduit run without pullboxes.



**Underground services from underground lines are explained here.**

**C. UNDERGROUND SERVICE FROM AN UNDERGROUND SYSTEM**

This page identifies what you must install if you are receiving this type of service connection. This type of connection will normally be used if you are receiving service from an underground system.

**You will install**

- riser to meter socket with elbow and bushing
- conductors to disconnect
- trench and conduit

\*check with your PNM field office for their trench and conduit requirements

**We will install**

- service cable
- terminations at socket
- meter(s)

**Requirements for connection to home.**

Select one of the following drawings, appropriate for the connection of the service to your home or pole.

- \* If the service will connect to your home, use DS-4-5.0.
- \* If the service is for a mobile home, use MS-5-2.0.

Refer to the following table to size the service entrance conduit for your home. Please contact your new service representative if you have any questions regarding conduit size.

<b>Residential Underground Service Entrance Conduit Size (Internal Diameter)</b>			
Service Distance (ft)	*125A Class Meter Socket	200A Class Meter Socket	320A Class Meter Socket
100' or Less	3"	3"	3"
Greater than 100'	3"	3"	3"

\*125A is only applicable for manufactured, mobile homes and replacing existing 100A or less meter socket.

**Requirements for meter sockets.**

Your meter socket can have a rating of 200 or 320 Amps.

- \* For a meter socket rated 200 Amps, use MS-2-2.0 or MS-2-5.0 (with the bypass feature).
- \* For a meter socket rated 320 Amps, use MS-3-7.0.

**There are special considerations for landscaping areas with underground utilities.**

Plan your schedule so that the construction of walls, fences, and driveways occurs after underground service installation. If walls, fences and driveways are constructed prior to the time the service connection is made, you may incur additional cost.

A conduit shall be provided by the customer under all driveways.

The lot must be at final grade prior to the service being installed. Proper coordination of landscape operations with construction can reduce costs for all involved.

## **Blank Page for Notes**

**Multiple Leased  
Residential Units**

# Multiple Leased Residential Units: Electric Service Requirements

**We want to work with you to supply your electrical needs.**

This chapter focuses on the requirements for apartments and mobile home parks with individually metered residential units. Master metered apartments are treated as a single business, and their electric service requirements are discussed in the chapter about single businesses. We want to provide our apartment developers and their contractors with the information they need to plan and receive electric service. We want to work with you and assist you, so that this process works smoothly.

**The procedures in this book enable a complex and regulated process to work for the many people involved.**

The following procedures and requirements are necessary because they provide a structure that allows a complex process to be completed in a predictable and efficient manner. We realize that the successful construction of apartments requires cooperation and scheduling among many entities, which could include contractors, utilities, municipalities, banks and others. Therefore, we are providing this document to

- \* promote mutual planning and scheduling
- \* promote fair and consistent treatment for you and your contractors
- \* ensure compliance with the requirements of the Public Regulation Commission
- \* coordinate with the requirements of local government inspection and permitting agencies regarding enforcement of the National Electrical Code (NEC), and the National Electrical Safety Code (NESC)
- \* ensure compliance with all applicable environmental laws

Our process to provide you with electricity is governed by several policies that are approved and monitored by the Public Regulation Commission. The complete text of these policies can be obtained from your new service representative. Most of these policies are included in summary form in the chapter of this document on "Policies", page 59. In this chapter, we provide you with the important information from these policies that affects the apartment developer.

All our procedures are developed to be in compliance with the PNM Line Extension Policy. This policy is established to ensure that all customers, including those desiring line extensions and existing rate payers, are treated fairly and consistently. However, this LXP does not apply to customers with expected loads greater than 500kW and who will ultimately take electric service under PNM Rate Schedule 4B (Large Power), 5B (Industrial Power) or 4000B (United States Governmental Special Contract). **In such situations, line extensions and service agreements will be established on an individual basis.**

## **What you need to know about the Line Extension Policy:**

- The Line Extension Policy governs the costs of building line extensions.
- You will need a line extension to provide electricity to your apartments.
- Your cost for a line extension is our estimated cost to design and build electric facilities to serve your development less any credits to which you are entitled.
- More information on credits can be read further in this section. (See Policies, page 59)

# Steps to Follow to Receive Electric Service for Your Individually Metered Apartments

The following process will enable you to receive electric service for your apartments. Don't forget to make arrangements for, and to plan service from other utilities that you want to serve your apartments (for example, gas, telephone, and/or cable television).

You may want to coordinate your need for construction power with your permanent line extension.

**If electricity is currently available on your site this process may be greatly simplified.**

**If power is already available on your property, you may not have to complete all of the following steps.** Check with your new service representative to determine which steps are appropriate for your situation.

## **1. Plan for Your Electric Service**

**Plan the physical layout and schedule of your electric service.**

Just as you must work with architectural and engineering plans for the construction of your apartment building, we must develop plans for the power lines that will supply electricity to your apartments. Give consideration to where you would like the power to be delivered to your building and the size of your electric service.

- \* How much electricity will your apartments or mobile home use?
- \* Where and when would you like construction power delivered to your site?
- \* Where are the appropriate locations for the transformer and meter?
- \* When do you need permanent power?

**We have many standard voltages to serve your needs.**

The following list shows the available voltages for apartment developers. The voltage that will best serve you depends on the maximum load to be served, the location of the load, the number of metering points, your future power requirements, the nature of your load, and your rate schedule. Your new service representative will work with you to determine how to best meet your needs.

- \* 120/240 volt, single-phase, three-wire pole-mounted transformer service for a demand of 75 kW or less, from an overhead system.
- \* 120/240 volt, single-phase, three-wire padmounted transformer service for a demand of 165 kW or less from a single-phase underground system or an overhead system.
- \* 120/208 volt, three-phase, four-wire padmounted transformer service for loads of 50 to 675 kW.
- \* 120/208 volt, three-phase, four-wire pole-mounted transformer service for a demand of 125 kW or less, from an overhead system.

**Provide protection for single-phase conditions, and design for available fault current.**

If you are receiving three-phase electric service, it is your responsibility to provide protection for your motors against the possibility of single-phase operation. Also, please reference drawing DM-4-11.0 for the maximum available fault current associated with your chosen voltage. You will need this fault current information to properly size your service entrance equipment.

**Consider how you will pay for your line extension.**

**Electric Line Extensions Are Not Free.** You need to consider this cost in the financial planning for your apartments.

**Any changes to the original design submitted to PNM could result in additional charges.**

## **2. Submit Your Specifications to Us**

[www.PNM.com/erequest](http://www.PNM.com/erequest)

**We need your specifications so that we may design the electric facilities to serve you.** All new service or upgrade requests require a Service Application be submitted to PNM. This is done through our on-line Electric Service eRequest system at [www.PNM.com/erequest](http://www.PNM.com/erequest). You'll be able to track your open requests and receive email notifications on the status of your request. Please submit your request as early as possible.

Electric service to apartments can be a very complex process with many variables. Please discuss and coordinate your specifications with us as early as possible and provide us with the following:

- \* a complete set of plans as bid for construction, including architectural plans, grading plans, riser diagram (indicating the size and type of phase and neutral conductors), site plan, landscape plans, and electrical and mechanical drawings, with all specifications and calculations. Please provide any plats in electronic format.
- \* service entrance conductor size and numbers of runs, if applicable (we must work with you to determine the number and size of conduits)
- \* main breaker panel rating
- \* interrupting rating of all disconnect devices
- \* connected NEC load and NEC estimated demand for each metering point
- \* service capacity-there are state and local requirements that require the stamp of an electrical engineer for some loads:
  - o The state of New Mexico-when service capacity exceeds 100 kVA single-phase or 225 kVA three-phase, requires plans, specifications and calculations to be stamped by an electrical engineer licensed to practice in New Mexico.
  - o City of Albuquerque and Bernalillo county-when service capacity exceeds 200 amps for single-phase or 50 kVA for three-phase, the electrical design shall be prepared and sealed by a registered professional engineer, licensed to practice in the State of New Mexico.
  - o Other cities or counties may have similar requirements. Check with your local inspection agencies. Refer to page 12 for phone numbers and addresses.
- \* legal description and lot location with recorded warranty deed of conveyance to owner
- \* building orientation on lot with distances from property lines
- \* existing easements on property
- \* proposed electric transformer and meter locations
- \* the customer is allowed a single point of service for grouped or ganged metering on each building

### **What you need to know about transformer and electric meter locations:**

- Ask your new service representative for meter and transformer locations.
- Transformers must be easily accessible by truck for operation and maintenance.
- Refer to drawing MS-7-1.0 for required working clearance around meters.
- Refer to drawing DS-7-16.12 for required working clearance around transformers.

**Consult with your new service representative before final decisions are made on your meter location.**

**Make sure your facilities are a safe distance from overhead lines.**

The National Electrical Safety Code (NESC) establishes clearances that must be maintained between power lines and buildings, signs, and other structures. **These clearances must be maintained regardless of easement boundaries.** When planning your facilities, please work with us to ensure that these required clearances are maintained.

**We will estimate the cost of the electrical facilities to serve you.**

We will contact you to discuss your new services requirements and related costs. There are three types of service connections that can be designed, depending on your situation. They are:

- \* overhead service from an overhead line
- \* customer-owned underground service from an overhead line
- \* underground service from an underground line

The customer will have the option to acquire their own private easements, which need to be verified by PNM at customer's expense. **The customer may request PNM to acquire these easements at the customer's expense, which will be paid in advance and is nonrefundable.** All easements or permits for governmental agencies must be acquired by PNM.

**We will comply with applicable environmental laws. The responsible protection of natural and cultural resources is a part of the cost of a line extension. This process can be lengthy depending on resources affected and land jurisdiction.**

**Trenching**

**See Trenching Policy, page 77.**

## **3. Develop Line Extension Agreement**

**The Line Extension Agreement is a contract for the cost of the line extension that will serve you.**

You will need to discuss your service options with your new service representative. We will let you know your cost for the permanent line extension that will serve you. You must pay our estimated cost to build the line extension, less any credits for which you are eligible. The two types of credits available are explained in the following section.

**Policy summaries may be found in the chapter entitled "Policies", page 59.**

The chapter on policies contains general summaries of policies that apply to all customer classes. Policies summarized in this chapter include:

- Line Clearances from Buildings, Signs, and Other Structures
- Access into PNM Equipment
- Customer Generation Systems
- Electric Line Extension Policy
- Metering Policy
- Trenching Policy

**When a line extension passes other unserved lots, the lot credit compensates the line extension customer for the service benefits to these lots.**

**If the customer believes the revenue from his project will exceed that identified on the revenue credit tables, he may sign a Revenue Credit Guarantee agreement to assume responsibility for meeting the higher revenue figure.**

## What you need to know about Lot Credits

There are four types of lot credits available to compensate the customer for benefits provided to other properties by the line extension:

Lot credits apply only to lots properly filed and recorded in the County Clerk's office. The customer will need to provide copies of this document to PNM in order to get this credit.

The lot credits include:

- \* **\$470** for each lot made ready for a service drop from either overhead or underground lines.
- \* **\$70** for each lot passed by the new underground backbone line, which will require padmount transformers and/or pedestals and/or secondary wire to provide future service.
- \* **\$340** for each lot passed by the new overhead backbone line, which will require pole-mounted transformers and/or secondary wire to provide future service.
- \* **\$130** for each lot made ready for a service drop by a new overhead transformer hung on an existing pole. This credit is in lieu of the \$470 credit mentioned above.

The total credit given will never exceed PNM's bid or the Customer Built Option Cost, whichever is lower.

## What you need to know about Revenue Credits

Up-front revenue credits will be determined by PNM.

In order to be eligible for revenue credits, final building plans must be provided to PNM.

**Any lot receiving a revenue credit is not eligible for a lot credit.**

Once defined, the revenue credit is firm. No revenue credit reconciliation will be made later.

A signed Revenue Credit Guarantee Agreement (RCGA) may be required for customers wishing to demonstrate revenue amounts exceeding those normally identified in the company's Revenue Estimation Table. The RCGA requires the customer to generate actual revenues, which meet or exceed the agreed-upon amount within the first 18 months of permanent electric service, or be billed for the difference. For further information on RCGA see your new service representative.



## **4. Make Payment for Electric Facilities**

PNM can schedule construction for the electric facilities we design to serve you once we have received applicable payments and agreements.

## **5. Construct Facilities to Receive Permanent Power**

This section provides information about what you need to build to receive permanent electric service. Although this section identifies requirements for most installations, all situations cannot be addressed in a book of this size. Please be sure to reach an agreement with your new service representative about your electric service facilities before you begin construction.

The facilities you need to install to receive electricity depend upon the location of your project, the type of service connection, the voltage you want to receive, and the size of your load. The following pages define our mutual construction responsibilities and list references to other drawings in this book for the facilities that you will install. Each page has the requirements for a different service connection as identified in the following list:

- A. Overhead Service from an Overhead Line
- B. Customer-Owned Underground Service from an Overhead Transformer Bank
- C. Padmount Transformer Service via a Primary Riser from an Overhead Line
- D. Padmount Transformer Service in an Underground Looped Area

**Different rules govern the provision of service to non-residential loads within your complex.**

Non-residential loads, such as laundry rooms, gymnasiums, or leasing offices within your apartment complex must be served in compliance with the rules for single businesses. Please discuss service options with your new service representative, to determine your options and cost for serving these loads.

### **What you need to know about electric permit releases:**

- In order to provide for public safety, all electrical facilities must be permitted, inspected and authorization to energize by the City, County, or State having jurisdiction to PNM.
- We cannot energize facilities that have not been permitted, passed inspection by the appropriate jurisdictional authority and released to PNM for energizing.  
The service entrance must also meet PNM Standards and specifications.
- We will connect your service within 10-12 working days of the time we receive the permit release and all the other conditions are met. Other conditions may include but are not limited to easement and right-of way, execution and completion of a line extension and permits.
- Your licensed electrical contractor can acquire and process your permit for electric service.

**Utility power lines can be hazardous! Maintain safe work clearances from power lines. See page 6 for more information.**

You must call for identification of underground utilities before you do any digging. New Mexico has a "One Call" system that enables you to call one phone number, and have the location of all underground utilities marked.

OSHA specifies minimum approach distances when working near overhead power lines. Generally an individual or equipment may not come closer than ten feet of overhead lines.

**The apartments are allowed a single point of service for grouped or ganged metering on each building. The Leased Mobile-Home Park must contact their new service representative to obtain gang and grouped meter instructions and meter spot.**

## A. Overhead Service from an Overhead Line

This page identifies what you must install if you are receiving this type of service connection. You will own and maintain the facilities that you are responsible for installing. References to other drawings in this book are provided where applicable. The following information cannot cover all situations, so be sure to verify your requirements with your new service representative.

### You will install

- service entrance riser and wiring to point of attachment
- meter socket or enclosure

### We will install

- service drop
- transformer(s)
- meter(s)

The following table references drawings in this book for your facilities.

Type of Installation	Single-Phase	Three-Phase
service entrance riser, service attachment to building	DS-4-3.0 or DS-4-4.0	DS-4-3.0 or DS-4-4.0
meter sockets	MS-4-1.0	MS-4-2.0

## B. Customer-Owned Underground Service from an Overhead Transformer Bank

The underground service cables and conduit, (extending from the point of service on your premises to the point on our pole where the connection is to be made) will be designed, installed, owned, maintained, and paid for by you. It is your responsibility that your facilities meet the size and depth requirements of the National Electrical Code (NEC). All conduit runs must be unbroken and contain appropriately sized conductor. Contact your new service representative for the placement of the secondary service conduit attached to our distribution pole. The conduit must not interfere with telephone or cable television company attachments. No switches or attachments other than the continuous run of conduit shall be placed on the pole. We will connect your service cable at our pole and install the meter. You or your contractor is responsible for all other connections, easements and wiring.

### You will install

- riser at PNM pole including applicable pole ground assembly
- trench and conduit
- service wires
- meter sockets

### We will install

- transformer(s)
- meter(s)
- terminations at PNM pole

The following table references drawings in this book for your facilities.

Type of Installation	Single-Phase	Three-Phase
Riser <sup>1</sup> at PNM's pole, trench, and conduit <sup>2</sup>	DS-4-9.0	DS-4-9.5
meter sockets	MS-4-1.0	MS-4-2.0

### NOTES:

- 1 - We will specify the quadrant location for the riser on PNM's pole.
- 2 - The service wire will be within a continuous unbroken conduit run without pullboxes.

## C. Padmount Transformer Service via a Primary Riser from an Overhead Line

This page identifies what you must install if you are receiving this type of service connection to one padmount transformer. You will own and maintain the facilities that you are responsible for installing. References to other drawings in this book are provided where applicable. The following information cannot cover all situations, so be sure to verify your requirements with your new service representative. **Your site should be at final grade, and you must stake the location for electric facilities before we begin construction.** Your requirements will be documented in a Standard Procedures letter that you will receive after you submit your plans to us, and before you sign an Electric Line Extension Agreement.

### You will install

- riser at PNM pole
- trench and primary conduit with pull string
- secondary conduit <sup>1</sup> with pullstring between the transformer and meter
- transformer pad
- meter sockets

### We will install

- primary cable and termination
- secondary wires between the transformer and meter
- transformer and terminations
- meter(s)

The following table references drawings in this book for your facilities.

Type of Installation	Single-Phase	Three-Phase
Riser <sup>2</sup> at PNM's pole, trench, and conduit <sup>3</sup>	DS-7-14.0	DS-7-15.0
transformer pad <sup>4</sup> and conduit stub outs <sup>5</sup>	DS-7-16.1	DS-7-16._*
meter sockets	MS-4-1.0	MS-4-2.0

\* Please contact your new service representative for information.

### NOTES:

- 1 - The service wire will be within a continuous unbroken conduit run without pullboxes.
- 2 - We will specify the quadrant location for the riser on PNM's pole.
- 3 - Trench and conduit must be inspected and approved before concrete (where required) is poured. Rigid galvanized, IMC or Schedule 40 (min.) PVC conduit may be used, but must be inspected and approved before backfilling.
- 4 - Transformer pad form, conduit placement, and pad location must be inspected and approved by PNM before concrete is poured.
- 5 - One primary conduit stub out as specified by PNM. Conduit must be buried a minimum of 42 inches, extend a minimum of 5 feet beyond the edge of the equipment pad, and be capped at both ends.

## D. Padmount Transformer Service in an Underground Looped Area

This page identifies what you must install if you are receiving this type of service connection. This type of connection will normally be used if you are receiving service from more than one padmount transformer. You will own and maintain the facilities that you are responsible for installing. References to other drawings in this book are provided where applicable. The following information cannot cover all situations, so be sure to verify your requirements with your new service representative. **Your site must be at final grade, and you must stake the location for electric facilities before we begin construction.** Your requirements will be documented in a Standard Procedures letter that you will receive after you submit your plans to us, and before you sign an Electric Line Extension Agreement.

### You will install

- secondary conduit <sup>1</sup> and trench with pull string between the transformer and meters
- transformer pad and conduit stub outs
- meter sockets

### We will install

- primary cable and trench <sup>4</sup>
- transformer and terminations
- metering
- secondary wires between transformer and meters

The following table references drawings in this book for your facilities.

Type of Installation	Single-Phase	Three-Phase
transformer pad <sup>2</sup> and conduit stub outs <sup>3</sup>	DS-7-16.1	DS-7-16.7
meter sockets	MS-4-1.0	MS-4-2.0

### NOTES:

- 1 - The service wire will be within a continuous unbroken conduit run without pullboxes.
- 2 - Transformer pad form, conduit placement, and pad location must be inspected and approved by PNM before concrete is poured.
- 3 - Two primary conduit stub outs as specified by PNM. Conduits must be buried a minimum of 42 inches, extend a minimum of 5 feet beyond the edge of the equipment pad, and be capped at both ends.
- 4 - Enclosures must be delivered to the local PNM Service Center. We will pre-wire the enclosure and deliver to your construction site. Please allow 10 working days for us to pre-wire the meter enclosure.

## **Blank Page for Notes**



# Residential Subdivisions: Electric Service Requirements

**We want to work with you to supply electricity for your subdivision.**

This chapter focuses on the requirements for residential developers. We want to provide developers and their contractors with the information they need to plan and receive electric service for their development. We want to work with you and assist you, so that this process works smoothly.

**The procedures in this book enable a complex and regulated process to work for the many people involved.**

The following procedures and requirements are necessary, because they provide a structure that allows a complex process to be completed in a predictable and efficient manner. We realize that the successful construction of a residential subdivision requires cooperation and scheduling among many entities, which could include contractors, utilities, municipalities, banks and others. Therefore, we provide this document to:

- \* promote mutual planning and scheduling
- \* promote fair and consistent treatment for you and your contractors
- \* ensure compliance with the requirements of the Public Regulation Commission
- \* coordinate with the requirements of local government inspection and permitting agencies regarding enforcement of the National Electrical Code (NEC), and the National Electrical Safety Code (NESC)
- \* ensure compliance with all applicable environmental laws

Our process to provide you with electricity is governed by several policies that are approved and monitored by the Public Regulation Commission. The complete text of these policies can be obtained from your new service representative. Most of these policies are included in summary form in the chapter of this document on "Policies", page 59. In this chapter, we provide you with the important information from these policies that affects the residential subdivision developer.

All our procedures are developed to be in compliance with the PNM Line Extension Policy. This policy is established to ensure that all customers, including those desiring line extensions and existing rate payers, are treated fairly and consistently.

The LXP states that PNM must design the minimum system needed to provide service to the customer. In regard to underground electric systems, the minimum system generally incorporates a looped design. The looped underground design is required to provide customers on this system with an acceptable electric restoration time should a failure occur in the underground cable.

## **What you need to know about the Line Extension Policy:**

- The Line Extension Policy governs the costs of building line extensions.
- You will need a line extension to provide electricity to your development.
- Your cost for a line extension is our estimated cost to design and build electric facilities to serve your development less any credits to which you are entitled.
- Initial credits are based on the policies.
- More information on credits can be read further in this section. (See Policies, page 59)



# Steps to Follow to Provide Electric Service to Your Subdivision

The following steps tell you how to obtain electric service for your subdivision. A book of this size cannot cover all situations. Please be sure to work with your new service representative to meet your needs. This book cannot take precedence over contracts that are developed for your project or the rules and regulations that govern line extensions. In most cases, you have the option to have telephone, cable TV and gas installed in the same trench as the PNM electric facilities. When joint trench utilities are planned for subdivisions, the customer will serve as the focal point for coordination of the project.

You may want to coordinate your need for construction power with your permanent line extension.

## **1. Plan for Electric Service**

**Consider the coordination of utility installation with your construction schedule.**

Just as you must work with construction plans for the development of your subdivision, we must develop plans for the power lines that will supply electricity to your subdivision. Give consideration to how best to coordinate power line construction with your site development. Standard voltage for residential customers is single-phase 120/240 volt service.

- \* Where are the power lines and transformers going to be installed?
- \* Where and when would you like the construction power for your development?
- \* How will your grading, curb, and road installation affect installation of power facilities?
- \* How will other utilities affect installation of power facilities?
- \* Are there electric facilities on site or will there be costs to construct electric lines to your site?
- \* Will there be utilities going under the roads and can they be installed prior to paving?

**Electric line extensions are not free.** You need to consider this cost in the financial planning for your subdivision.

## 2. Submit Your Specifications to Us

[www.PNM.com/erequest](http://www.PNM.com/erequest)

**We need your plans, so that we can design the electric facilities to serve your subdivision.**

All new service or upgrade requests require a Service Application be submitted to PNM. This is done through our on-line Electric Service eRequest system at [www.PNM.com/erequest](http://www.PNM.com/erequest). You'll be able to track your open requests and receive email notification on the status of your request. Please submit your request as early as possible.

Electric service to subdivisions can be very complex with many variables. Don't forget to plan for electric service to such things as street lights, power for sprinkler systems or wells and power to guard houses, as required. Please discuss and coordinate your specifications with us as early as possible and provide us with the following:

- \* site plan and filed plat in electronic format
- \* proposed public utility easement as required by the utilities
- \* existing easements of record on the property under development
- \* grading plan
- \* driveway locations (this is essential for zero lot line and town house construction)
- \* average square footage of future homes
- \* type of heating and cooling system for future homes
- \* special electrical requirements
- \* landscape plan
- \* plans indicating retaining walls and concrete lined drainage areas
- \* street light locations as determined by the local authority
- \* any other specialty plans
- \* proposed meter locations when possible

**Electric meter locations are a sensitive issue during house construction. Please let your home builders know that there are limitations regarding electric meter locations.**

### **What you need to know about transformer and electric meter locations:**

- Ask your new service representative for meter and transformer locations.
- Meters must be easily accessible for reading and maintenance.
- Transformers must be easily accessible by truck for operation and maintenance.
- Refer to drawing MS-7-1.0 for required working clearance around meters.
- Refer to drawing DS-7-16.12 for required working clearance around transformers.
- Refer to drawing DS-9-17.0 for required working clearance around switchgear.

**Make sure your facilities are a safe distance from overhead lines.**

The National Electrical Safety Code (NESC) establishes clearances that must be maintained between power lines and buildings, signs, and other structures. **These clearances must be maintained regardless of easement boundaries.** When planning your facilities, please work with us to ensure that these required clearances are maintained.

**The pre-design conference is a key coordination opportunity.**

The Pre-design Conference includes utilities, contractors, and any other concerned party to meet and discuss details of the project. Items that are discussed are not limited, and typically include our proposed electric system design, construction scheduling, utility location, street crossings, customer staking responsibilities, joint use of easements by utilities, barricade requirements for trenches, dust control, and responsibility for opening and closing trenches. Decisions made during this conference will be incorporated into formal construction agreements.

**We will estimate the cost of the electrical facilities to serve you.**

After we receive your plans and typically after the pre-design conference, new service representative will contact you to discuss upfront costs related to your line extension and to assist you if required in your acquisition of necessary right-of-way to provide power to your development.

**We will comply with applicable environmental laws. The responsible protection of natural and cultural resources is a part of the cost of a line extension. This process can be lengthy depending on resources affected and land jurisdiction.**

Trenching

■ See Trenching Policy, page 77.

### **3. Develop Line Extension Agreement**

**The Line Extension Agreement is a contract for the cost of your line extension.**

You will need to discuss your service options with your new service representative. We will let you know your cost for the permanent line extension that will serve you. You must pay our estimated cost to build the line extension, less any credits for which you are eligible. The two types of credits available are explained in the following section.

**Policy summaries may be found in the chapter entitled “Policies”, page 59.**

The chapter on policies contains general summaries of policies that apply to all customer classes. Policies summarized in this chapter include:

- Line Clearances from Buildings, Signs, and Other Structures
- Access into PNM Equipment
- Customer Generation Systems
- Electric Line Extension Policy
- Metering Policy
- Trenching Policy

**Make sure your facilities are a safe distance from overhead lines.**

The National Electrical Safety Code (NESC) establishes clearances that must be maintained between power lines and buildings, signs, and other structures. **These clearances must be maintained regardless of easement boundaries.** When planning your facilities, please work with us to ensure that these required clearances are maintained.

**When a line extension passes other unserved lots, the lot credit compensates the line extension customer for the service benefits to these lots.**

## What you need to know about Lot Credits

There are four types of lot credits available to compensate the customer for benefits provided to other properties by the line extension.

Lot credits apply only to lots properly filed and recorded in the County Clerk's office. The customer will need to provide copies of this document to PNM in order to get this credit.

The lot credits include:

- \* **\$470** for each lot made ready for a service drop from either overhead or underground lines.
- \* **\$70** for each lot passed by the new underground backbone line, which will require padmount transformers and/or pedestals and/or secondary wire to provide future service.
- \* **\$340** for each lot passed by the new overhead backbone line, which will require pole-mounted transformers and/or secondary wire to provide future service.
- \* **\$130** for each lot made ready for a service drop by a new overhead transformer hung on an existing pole. This credit is in lieu of the \$470 credit mentioned above.

The total credit given will never exceed PNM's bid or the Customer Built Option Cost, whichever is lower.

**If the customer believes the revenue from his project will exceed that identified on the revenue credit tables, he may sign a Revenue Credit Guarantee Agreement for meeting the higher revenue figure.**

## What you need to know about Revenue Credits

Up-front revenue credits will be determined by PNM.

In order to be eligible for revenue credits, final building plans must be provided to PNM.

**Any lot receiving a revenue credit is not eligible for a lot credit.**

Once defined, the revenue credit is firm. No revenue credit reconciliation will be made later.

A signed Revenue Credit Guarantee Agreement (RCGA) may be required for customers wishing to demonstrate revenue amounts exceeding those normally identified in the company's Revenue Estimation Table. The RCGA requires the customer to generate actual revenues, which meet or exceed the agreed-upon amount within the first 18 months of permanent electric service, or be billed for the difference. For further information on RCGA see your new service representative.

## **4. Make Payment for Electric Facilities**

PNM can schedule construction for the electric facilities we design to serve you once we have received applicable payments and agreements.

## **5. Develop Your Subdivision**

You will develop your site into a residential subdivision, ready for home builders to begin their job. We will construct the electrical system that will allow future homes to receive electricity.

To ensure that we meet your schedule, please keep your new service representative informed of the status of your subdivision and any changes that may arise.

**This explains what you will do.**

All grading operations shall be completed before trenching. Please also schedule major landscape filling operations to follow line installation. Proper coordination of landscape operations with construction can reduce costs for all involved.

In general, all curb, gutter, main water and main sewer systems must be installed, and the grading must be within 6 inches of final grade before PNM installation can begin. All construction activities must be in compliance with the agreements reached in the pre-design meeting. It is very expensive to relocate facilities after construction. You will pay this expense, if the relocation results from your requested changes or lack of compliance with PNM requirements.

**This explains what we will do.**

We will build facilities to provide 120/240 volt electric service to each lot within your subdivision. Meters and service connections to each home will be made in the future, after the homes are constructed and ready for occupation.

## **Blank Page for Notes**



# Single Businesses: Electric Service Requirements

**We want to work with you to supply your electrical needs.**

This chapter focuses on the requirements for commercial businesses. Master metered apartments are considered to be a single commercial business. Requirements for individually metered apartments are discussed in a separate chapter. We want to provide our business customers and their contractors with the information they need to plan and receive electric service. We want to work with you and assist you, so that this process works smoothly.

**The procedures in this book enable a complex and regulated process to work for the many people involved.**

The following procedures and requirements are necessary, because they provide a structure that allows a complex process to be completed in a predictable and efficient manner. We realize that the successful development of a new business requires cooperation and scheduling among many entities, which could include contractors, utilities, municipalities, banks and others. Therefore, we provide this document to

- \* promote mutual planning and scheduling
- \* promote fair and consistent treatment for you and your contractors
- \* ensure compliance with the requirements of the Public Regulation Commission
- \* coordinate with the requirements of local government inspection and permitting regarding enforcement of the National Electrical Code (NEC), and the National Electrical Safety Code (NESC)
- \* ensure compliance with all applicable environmental laws

Our process to provide you with electricity is governed by several policies that are approved and monitored by the Public Regulation Commission. The complete text of these policies can be obtained from your new service representative. Most of these policies are included in summary form in the chapter of this document on "Policies", page 59. In this chapter, we provide you with the important information from these policies that affects the single commercial businesses.

All our procedures are developed to be in compliance with the PNM Line Extension Policy. This policy is established to ensure that all customers, including those desiring line extensions and existing rate payer, are treated fairly and consistently. However, this LXP does not apply to customers, with expected loads greater than 500 kW and who will ultimately take electric service under PNM Rate Schedule 4B (Large Power), 5B (Industrial Power) or 4000B (United States Government Special Contract). **In such situations, line extensions and service agreements will be established on an individual basis.**

## What you need to know about the Line Extension Policy:

- The Line Extension Policy governs the costs of building line extensions.
- You will need a line extension to provide electricity to your business.
- Your cost for a line extension is our estimated cost to design and build electric facilities to serve your development less any credits to which you are entitled.
- More information on credits can be read further in this section. (See Policies, page 59)



# Steps to Follow to Receive Electric Service for Your Business

The following steps tell you how to obtain electric service for your business. You should coordinate your need for construction power with your permanent line extension, and with your financing (if applicable). The following process will enable you to receive electric service. Don't forget to make arrangements for, and to plan service from, other utilities that you want to serve your business (for example, gas, phone, and/or cable television).

**If electricity is currently available on your site this process is greatly simplified.**

If power is already available on your property, you may not have to complete all of the following steps. **Special consideration should be taken if installing or upgrading to 300 amp or greater service and/or adding a refrigerated air conditioning system.** Check with your new service representative to determine which steps are appropriate for your situation.

## **1. Plan for Your Electric Service**

**Plan the physical layout and schedule of your electric service.**

Just as you must work with architectural and engineering plans for the construction of a new building, we must develop plans for the power lines that will supply electricity to your business. Give consideration to where you would like the power to be delivered to your building and the size of your electric service.

- \* How much electricity will your business use including securing easements?
- \* Where and when would you like construction power delivered to your site?
- \* Where are the appropriate locations for the transformer and meter?
- \* When do you need permanent power to your building?

### **Special consideration for remodels and or additions:**

- \* Will the existing meters and transformers accommodate additional load, **especially if changing cooling system from evaporative to refrigerated air conditioning?**
- \* If the existing service is provided from overhead transformers, will there be enough additional loads to require padmount transformers?
- \* Will the meter location need to change?

**Please be aware that all work requested after normal working hours and on weekends will be billed to the customer requesting this work on a non-refundable basis.**

**We have many standard voltages to serve your needs.**

The following list contains the available voltage options provided by PNM. The voltage that will best serve you depends on the maximum load to be served, the location of the load, the number of metering points, your future power requirements, the nature of your load, and your rate schedule. Your new service representative will work with you to determine how to best meet your needs.

- \* 120/240 volt, single-phase, three-wire pole-mounted transformer service for a demand of 50 kW or less, from an overhead system.
- \* 120/240 volt, single-phase, three-wire padmounted transformer service for a demand of 75 kW or less from a single-phase underground system or an overhead system.
- \* 240 volt, three-phase, four-wire pole-mounted transformer service for a demand of 50 kW or less, from an overhead system.
- \* Combination of 240 volt, three-phase, four-wire 120/240 volt, single-phase, three-wire pole-mounted transformer service for a demand of 75 kW or less from an overhead system. With this type of service, individual single-phase or three-phase demands shall not exceed 50 kW.
- \* 120/208 volt, three-phase, four-wire padmounted transformer service with single point secondary metering for loads of 50 to 500 kW.
- \* 120/208 volt, three-phase, four-wire pole-mounted transformer service for a demand of 125 kW or less, from an overhead system.
- \* 277/480 volt, three-phase, four-wire pole-mounted transformer service for a demand of 125 kW or less, from an overhead system.
- \* 277/480 volt, three-phase, four-wire furnished for all loads in the Downtown and Urban Renewal Area in Albuquerque. Applies to all development in the area bounded by Lomas Avenue on the north, Lead Avenue on the south, the railroad tracks on the east, and 8th street on the west. This book does not contain requirements for electric service in this area. Contact your new service representative for electric service requirements.
- \* 277/480 volt, three-phase, four-wire padmounted transformer service with single point secondary metering for loads of 50 to 1,500 kW.
- \* For loads exceeding 500 kW, service may by mutual agreement be furnished at our available transmission or distribution voltage of 4,160 volts or higher. Primary metered service is not available for Customers who are going to further meter and distribute power to electrical systems not under the Customer's ownership and control.
- \* Three-phase commercial/industrial subdivisions designed to provide three-phase underground service are subject to certain restrictions for single-phase customers. Since these systems are designed to be operated as three-phase systems, the installation of single-phase transformers will not be permitted. Developers desiring the availability of single-phase service via single-phase transformers at certain properties may elect to have the system designed and constructed such that a separate cable is installed for single-phase service, in addition to the cables installed for the three-phase service.

**Provide protection for single phase conditions, and design for available fault current.**

If you are receiving three-phase electric service, it is your responsibility to provide protection for your motors against the possibility of single-phase operation. Also, please reference drawing DM-4-11.0 for the maximum available fault current associated with your chosen voltage. You will need this fault current information to properly size your service entrance equipment.

**Consider how you will pay for your line extension.**

You may incur cost for the Electric Line Extension You need to consider this cost in the financial planning for your business.

**Any changes to the original design submitted to PNM could result in additional charges.**

## **2. Submit Your Specifications to Us**

[www.PNM.com/erequest](http://www.PNM.com/erequest)

**We need your specifications so that we may design the electric facilities to serve you.**

All new service or upgrade requests require a Service Application be submitted to PNM. This is done through our on-line Electric Service eRequest system at [www.PNM.com/erequest](http://www.PNM.com/erequest). You'll be able to track your open requests and receive email notifications on the status of your request. Please submit your request as early as possible.

Electric service to your business can be a very complex process with many variables. Please discuss and coordinate your specifications with us as early as possible and provide us with the following:

- \* a complete set of plans as bid for construction, including architectural plans, grading plans, riser diagram (indicating the size and type of phase and neutral conductors), site plan, landscape plans, and electrical and mechanical drawings, with all specifications and calculations. Please provide any plats in digital format, if possible and provide us with the following:
  - \* service entrance conductor size and numbers of runs
  - \* main breaker panel rating
  - \* interrupting rating of all disconnect devices
  - \* connected NEC load and NEC estimated demand for each metering point
  - \* service capacity-there are state and local requirements that require the stamp of an electrical engineer for some loads:
    - o The state of New Mexico-when service capacity exceeds 100 kVA single-phase or 225 kVA three-phase, requires plans, specifications and calculations to be stamped by an electrical engineer licensed to practice in New Mexico.
    - o City of Albuquerque and Bernalillo county-when service capacity exceeds 200 amps for single-phase or 50 kVA for three-phase, the electrical design shall be prepared and sealed by a registered professional engineer, licensed to practice in the State of New Mexico.
    - o Other cities or counties may have similar requirements. Check with your local inspection agencies. Refer to page 12 for phone numbers and addresses.
- \* legal description and lot location with recorded warranty deed of conveyance to owner
- \* building orientation on lot with distances from property lines
- \* existing easements on property
- \* for primary meters, see page 51 for special submittal requirements
- \* proposed electric meter location
- \* specification's on customer generation systems (See Policy on page 78)
- \* The customer is only allowed a single point of service for grouped or ganged metering on each building

**Electric meter and transformer locations are sensitive issues during construction. Please let your business tenants know that there are limitations regarding electric meter and transformer locations.**

### **What you need to know about transformer and electric meter locations:**

- Ask your new service representative for a meter and transformer locations.
  - Transformers must be easily accessible for operation and maintenance.
  - Refer to drawing MS-7-1.0 and MS-7-2.0 for required working clearance around metering installations.
  - Refer to drawing DS-7-16.12 for required working clearance around transformers.
- Consult with your new service representative before final decisions are made on you meter location.**

**Make sure your facilities are a safe distance from overhead lines.**

The National Electrical Safety Code (NESC) establishes clearance that must be maintained between power lines and buildings, signs, and other structures. **These clearances must be maintained regardless of easement boundaries.** When planning your facilities, please work with us to ensure that these required clearances are maintained.

**We will estimate the cost of the electrical facilities to serve you.**

We will contact you to discuss your new services requirements and related costs. There are three types of service connections that can be designed, depending on your situation. They are

- \* overhead service from an overhead line
- \* customer-owned underground service from an overhead line
- \* underground service from an underground line

The customer will have the option to acquire their own private easements, which need to be verified by PNM at customer's expense. **The customer may request PNM to acquire these easements at the customer's expense, which will be paid in advance and is nonrefundable.** All easements or permits for governmental agencies must be acquired by PNM.

**We will comply with applicable environmental laws. The responsible protection of natural and cultural resources is a part of the cost of a line extension. This process can be lengthy depending on resources affected and land jurisdiction.**

**Trenching**

**See Trenching Policy, page 77**

### **3. Develop Line Extension Agreement**

**The Line Extension Agreement is a contract for the cost of the line extension that will serve you.**

You will need to make some decisions before the Agreement can be completed. We will let you know your cost for the permanent line extension that will serve you. You must pay our estimated cost to build the line extension, less any credits for which you are eligible. The two types of credits available are explained in the following section.

**Policy summaries may be found in the chapter entitled “Policies”, page 59.**

The chapter on policies contains general summaries of policies that apply to all customer classes. Policies summarized in this chapter include:

- Line Clearances from Buildings, Signs, and Other Structures
- Access into PNM Equipment
- Customer Generation Systems
- Electric Line Extension Policy
- Metering Policy
- Trenching Policy

### **What you need to know about Lot Credits**

**When a line extension passes other unserved lots, the lot credit compensates the line extension customer for the service benefits to these lots.**

There are four types of lot credits available to compensate the customer for benefits provided to other properties by the line extension.

Lot credits apply only to lots properly filed and recorded in the County Clerk's office. The customer will need to provide copies of this document to PNM in order to get this credit.

The lot credits include:

- \* **\$470** for each lot made ready for a service drop from either overhead or underground lines.
- \* **\$70** for each lot passed by the new underground backbone line, which will require padmount transformers and/or pedestals and/or secondary wire to provide future service.
- \* **\$340** for each lot passed by the new overhead backbone line, which will require pole-mounted transformers and/or secondary wire to provide future service.
- \* **\$130** for each lot made ready for a service drop by a new overhead transformer hung on an existing pole. This credit is in lieu of the \$470 credit mentioned above.

The total credit given will never exceed PNM's bid or the Customer Built Option Cost, whichever is lower.

If the customer believes the revenue from his project will exceed that identified on the revenue credit tables, he may sign a Revenue Credit Guarantee Agreement to assume responsibility for meeting the higher revenue figure.

## What you need to know about Revenue Credits

Up-front revenue credits will be determined by PNM. **Revenue credits do not apply for customer with loads greater than 500 kW. For this type of service, please see your new service representative regarding investment credit criteria and requirements.**

In order to be eligible for revenue credits, final building plans must be provided to PNM.

**Any lot receiving a revenue credit is not eligible for a lot credit.**

Once defined, the revenue credit is firm. No revenue credit reconciliation will be made later.

A signed Revenue Credit Guarantee Agreement (RCGA) may be required for customers wishing to demonstrate revenue amounts exceeding those normally identified in the company's Revenue Estimation Table. The RCGA requires the customer to generate actual revenues, which meet or exceed the agreed-upon amount within the first 18 months of permanent electric service, or be billed for the difference. For further information on RCGA see your new service representative

## 4. Make Payment for Electric Facilities

PNM can schedule construction for the electric facilities we design to serve you once we have received applicable payments and agreements.

## 5. Construct Facilities to Receive Permanent Power

This section provides information about what you need to build to receive electric service. Although this section identifies requirements for most installations, all situations cannot be addressed in a book of this size. Please be sure to reach an agreement with your new service representative about your electric service facilities before you begin construction.

The facilities you need to install to receive electricity depend upon the type of service connection, the voltage you want to receive, and the size of your load. The following pages define our mutual construction responsibilities and list references to other drawings in this book for the facilities that you will install. Each page has the requirements for a different service connection as identified in the following list:

- A. Overhead Service from an Overhead Line;
- B. Customer-Owned Underground Service from an Overhead Transformer Bank;
- C. Padmount Transformer Service via a Primary Riser from an Overhead Line;
- D. Padmount Transformer Service in an Underground Looped Area;
- E. Primary Metered Service.
- F. Serving Commercial Customers across the Street Right-of-Way from an Overhead System.

### **What you need to know about electric permit releases:**

- In order to provide for public safety, all electrical facilities must be permitted, inspected and authorization to energize granted by the City, County, or State having jurisdiction to PNM.
- We cannot energize facilities that have not been permitted, passed inspection by the appropriate jurisdictional authority and release to PNM for energizing. The service entrance must also meet PNM Standards and specifications.
- We will connect your service within 10-12 working days of the time we receive the release.
- Your licensed electrical contractor can acquire and process your permit for electric service.

**Utility power lines can be hazardous! Maintain safe work clearances from power lines. See page 6 for more information.**

You must call for identification of underground utilities before you do any digging. New Mexico has a "One Call" system that enables you to call one phone number, and have the location of all underground utilities marked.

OSHA specifies minimum approach distances when working near overhead power lines. Generally an individual or equipment may not come closer than ten feet of overhead lines.

## A. Overhead Service from an Overhead Line

**This explains what you own, install, and maintain.**

You will furnish and install an appropriate point of attachment. We will install, own, and maintain the service wires up to the point of attachment on your structure. It is your responsibility to install and maintain all other wiring and equipment past the point of attachment, except for the electric meter. The following information cannot cover all situations, so be sure to verify your requirements with your new service representative.

### You will install

- service entrance riser and wiring beyond the point of attachment
- meter socket or enclosure

### We will install

- service drop
- transformer(s)
- meter(s)

The following table references drawings in this book for your facilities.

**Requirements for your service riser and connections to your business.**

Type of Installation		Single-Phase	Three-Phase
Service entrance riser, service attachment to: (choose the one that fits your installation)	building	DS-4-3.0 or DS-4-4.0	DS-4-3.0 or DS-4-4.0
	service pole	DS-4-8.0	*
meter socket or enclosure: (choose the one that fits your installation)	200 Amp	MS-2-5.0	MS-2-6.0
	300 Amp	MS-3-7.0	MS-3-8.0 A
	>300 Amp	MS-3-7.0	MS-3-7.5 MS-3-10.0
	ganged meters	MS-4-1.0	*

\* Please contact your new service representative for information.

## B. Customer-Owned Underground Service from an Overhead Transformer Bank

It is your responsibility that your facilities meet the size and depth requirements of the National Electrical Code (NEC). The conduit must not interfere with telephone or cable television company attachments. No switches or attachments other than the continuous run of conduit shall be placed on the pole. We will connect your service cable at our pole and install the meter. You or your contractor is responsible for all other connections, easements and wiring.

### You will install

- riser at PNM pole including applicable pole ground assembly
- trench and conduit
- service wires
- meter socket or enclosure

### We will install

- transformer(s)
- meter(s)
- terminations at PNM pole

The following table references drawings in this book for your facilities.

**Requirements for your service riser and connections to your business.**

Type of Installation		Single-Phase	Three-Phase
Riser <sup>1</sup> at PNM's pole, trench, and conduit <sup>2</sup>		DS-4-9.0 or DS-4-10.0	DS-4-9.5
meter socket or enclosure: (choose the one that fits your installation)	200 Amp	MS-2-5.0	MS-2-6.0
	300 Amp	MS-3-7.0	MS-3-8.0 A
	>300 Amp	MS-3-7.0	MS-3-7.5 MS-3-10.0
	pedestal meter	MS-5-3.0 or MS-5-2.0	MS-5-5.0 or MS-5-3.0
	ganged meters	MS-4-1.0	*

\* Please contact your new service representative for information.

### NOTES:

- 1 - We will specify the quadrant location for the riser on PNM's pole.
- 2 - The service wire will be within a continuous unbroken conduit run without pullboxes.



## C. Padmount Transformer Service via a Primary Riser from an Overhead Line

This section identifies what you must install if you are receiving this type of service connection to one padmount transformer. You will own and maintain the facilities that you are responsible for installing. References to other drawings in this book are provided where applicable. The following information cannot cover all situations, so be sure to verify your requirements with your new service representative. **Your site should be at final grade, and you must stake the location for electric facilities before we begin construction.** Your requirements will be documented in a Standard Procedures letter that you will receive after you submit your plans to us, and before you sign an Electric Line Extension Agreement.

### You will install

- riser at PNM pole
- trench and primary conduit with pull string <sup>1</sup>
- secondary wires and conduit <sup>2</sup> between the transformer and meter
- transformer pad
- meter pad (if required)
- meter socket or enclosure

### We will install

- primary cable and terminations
- transformer and terminations
- meter(s)

The following table references drawings in this book for your facilities.

**Requirements for your service riser and connections to your business.**

Type of Installation		Single-Phase	Three-Phase
Riser <sup>3</sup> at PNM's pole, trench, and conduit <sup>4</sup>		DS-7-14.0	DS-7-15.0
transformer pad <sup>5</sup>		DS-7-16.1	DS-7-16._*
meter pad (if required)		NA	DS-7-17._* or MS-3-16.0
meter socket or enclosure: (choose the one that fits your installation)	200 Amp	MS-2-5.0	MS-2-6.0
	300 Amp	MS-3-7.0	MS-3-8.0
	>300 Amp	MS-3-7.0	MS-3-10.0 MS-3-11.0 <sup>6</sup>
	pedestal meters	MS-5-3.0 or MS-5-2.0	MS-5-5.0 or MS-5-3.0
	ganged meters	MS-4-1.0	*

\* Please contact your new service representative for information.

#### NOTES:

- 1 - For installation across street right-of-way see page 52.
- 2 - The cable from the transformer to the meter socket or enclosure will be within a continuous unbroken conduit run.
- 3 - We will specify the quadrant location for the riser on PNM's pole.
- 4 - Trench and PVC conduit must be inspected and approved before concrete is poured. Rigid galvanized or IMC conduit may be used, but must be inspected and approved before backfilling.
- 5 - Transformer pad form, conduit placement, and pad location must be inspected and approved by PNM before concrete is poured.
- 6 - Enclosures must be delivered to the local PNM Service Center. We will pre-wire the enclosure and deliver to your construction site. Please allow 10 working days for us to pre-wire the meter enclosure.

## D. Padmount Transformer Service in an Underground Looped Area

This section identifies what you must install if you are receiving this type of service connection. This type of connection will normally be used if you are receiving service from more than one padmount transformer. You will own and maintain the facilities that you are responsible for installing. References to other drawings in this book are provided where applicable. The following information cannot cover all situations, so be sure to verify your requirements with your new service representative. **Your site must be at final grade, and you must stake the location for electric facilities before we begin construction.** Your requirements will be documented in a Standard Procedures letter that you will receive after you submit your plans to us, and before you sign an Electric Line Extension Agreement.

### You will install

- secondary wires, trench, and conduit <sup>1</sup> between the transformer and meter
- transformer pad and conduit stub outs
- meter pad (if required)
- meter socket or enclosure

### We will install

- primary cable and trench <sup>2</sup>
- transformer
- terminations at transformer
- meter(s)
- primary riser

The following table references drawings in this book for your facilities.

Type of Installation		Single-Phase	Three-Phase
transformer pad <sup>3</sup> and conduit stubouts <sup>4</sup>		DS-7-16.1	DS-7-16.7 or DS-7-17.6
meter pad (if required)		NA	DS-7-17.6 or MS-3-16.0
meter socket or enclosure: (choose the one that fits your installation)	200 Amp	MS-2-5.0	MS-2-6.0
	300 Amp	MS-3-7.0	MS-3-8.0
	>300 Amp	MS-3-7.0	MS-3-10.0 MS-3-11.0 <sup>5</sup>
	pedestal meter	MS-5-3.0 or MS-5-2.0	MS-5-5.0 or MS-5-3.0
	ganged meters	MS-4-1.0	*

\* Please contact your new service representative for information.

### NOTES:

- 1 - The cable from the service entrance to the meter socket will be within a continuous unbroken conduit run.
- 2 - Customer will provide trench for joint utilities. See DS-10-8.0.
- 3 - Transformer pad form, conduit placement, and pad location must be inspected and approved by PNM before concrete is poured.
- 4 - Two 4 inch primary conduit stubouts as specified by PNM. Conduits must be buried a minimum of 42 inches, extend a minimum of 5 feet beyond the edge of the equipment pad, and capped at both ends.
- 5 - Enclosures must be delivered to the local PNM Service Center. We will pre-wire the enclosure and deliver to your construction site. Please allow 10 working days for us to pre-wire the meter enclosure.

## E. Primary Metered Service

This page identifies what you must install if you are receiving this type of service connection. You will own and maintain the facilities that you are responsible for installing. References to other drawings in this book are provided where applicable. The following information cannot cover all situations, so be sure to verify your requirements with your new service representative.

This type of connection requires special submittals during the planning stages of your project. At least 90 days prior to the construction start date, provide us with

- \* drawings showing the location and arrangement of required PNM facilities, your service entrance equipment and conductors, and information on easements and right-of-way
- \* one line diagram of the proposed electrical system stamped by an electrical engineer licensed in the State of New Mexico
- \* manufacturer, catalog number, and electrical ratings of gang-operated primary loadbreak/disconnect switch
- \* manufacturer and type of overcurrent protective device
- \* electrical time-current characteristic curves of proposed overcurrent protective devices

### Underground Primary Metered Service

You will install the following:

- \* Trench and conduit from our switchgear or riser pole to your metering enclosure and your gang operated primary load break disconnect switch. We will specify the quadrant for the riser on PNM's pole. For installation under street right-of-way see new service representative.
- \* Primary cables and terminations from the load side of the primary meter to the load break disconnect switch.
- \* Primary meter enclosure (MS-3-17.0 with MS-2-7.0 or MS-3-3.0), which must be delivered to the local PNM Service Center. We will pre-wire the enclosure and deliver to your construction site. Please allow 10 working days for us to pre-wire the meter enclosure.
- \* Meter enclosure pad per MS-3-21.0 and MS-7-2.0.
- \* Metal-enclosed three-phase gang-operated load break disconnect switch, which must be on the load side of the meter. Switch must be accessible, readily and safely operable by untrained personnel, and must be mechanically interlocked to prevent access to energized parts in the main overcurrent device.
- \* Metal-enclosed main overcurrent device or feeder overcurrent device on the load side of the switch (DS-7-15.1). Interlocks must be provided in accordance with the NEC to prevent access to energized parts if the switch is closed.
- \* All other devices on the load side of the primary meter.

We will install and/or provide primary metering, cable and terminations from our system to the line side of the primary metering equipment, and review and approval of your overcurrent protection.

## **F. Serving Commercial Customers across the Street Right-of-Way from an Overhead System.**

In an area where the local governing ordinances do not allow building of overhead lines, and when a radial extension makes sense, line extensions to commercial customers from an overhead system located on the opposite side of the street shall be constructed as follows:

### **We will install:**

- 1) PNM will install a new or use an existing pole whichever is most cost effective to build a riser, then will install schedule 40 PVC conduit from the base of riser pole crossing the street (via boring and/or trenching) to the customer property line per DSC section 7 applicable drawings. The property line is defined as the separation point between PNM conduit and customer owned conduit. This designates who is responsible for the maintenance of the conduit if something should ever happen to it.
- 2) PNM will install a pull box if necessary on customer property line based on technical or operational calculations or procedures respectively (i.e. cable pulling calculations and cable replacement cost evaluations due to a cable fault or conduit damage). Pullbox installation in the customer property must be located where it can be easily accessible by line truck.
- 3) PNM will install transformer and meter. Transformer installation in the customer property must be located where it can be easily accessible by line truck.
- 4) PNM will pull and terminate the cables from transformer primary compartment to the top of riser pole.

### **You will install:**

- 1) Customer shall continue the schedule 40 PVC conduit from the property line to the transformer primary compartment per DSC section 7 applicable drawings.
- 2) Customer shall install transformer pad based per DSC section 7 applicable drawings and construction letter.

**Commercial/Industrial  
Subdivisions**

# Commercial/Industrial Subdivisions: Electric Service Requirements

**We want to work with you to supply electricity for your development.**

This chapter focuses on the requirements for commercial/industrial subdivisions. We want to provide developers and their contractors with the information they need to plan and receive electric service for their development. We want to work with you and assist you, so that this process works smoothly.

**The procedures in this book enable a complex and regulated process to work for the many people involved.**

The following procedures and requirements are necessary, because they provide a structure that allows a complex process to be completed in a predictable and efficient manner. We realize that the successful construction of commercial/industrial subdivision requires cooperation and scheduling among many entities, which could include contractors, utilities, municipalities, banks and others. Therefore, we provide this document to:

- \* promote mutual planning and scheduling
- \* promote fair and consistent treatment for you and your contractors
- \* ensure compliance with the requirements of the Public Regulation Commission
- \* coordinate with the requirements of local government inspection and permitting agencies regarding enforcement of the National Electrical Code (NEC), and the National Electrical Safety Code (NESC)
- \* Ensure compliance with all applicable environmental laws

Our process to provide you with electricity is governed by several policies that are approved and monitored by the Public Regulation Commission. The complete text of these policies can be obtained from your new service representative. Most of these policies are included in summary form in the chapter of this document on "Policies", page 59. In this chapter, we provide you with the important information from these policies that affects the business subdivision developer.

All our procedures are developed to be in compliance with the PNM Line Extension Policy. This policy is established to ensure that all customers, including those desiring line extensions and existing rate payers, are treated fairly and consistently. However, this LXP does not apply to customers with expected loads greater than 500 kW and who will, in the Company's opinion, ultimately take electric service under PNM Rate Schedule 4B (Large Power), 5B (Industrial Power) or 4000B (United States Governmental Special Contract). **In such situations, for these customers line extensions and service agreements will be established on an individual basis.**

The LXP states that PNM must design the minimum system needed to provide service to the customer. In regard to underground electric systems, the minimum system generally incorporates a looped design. The looped underground design is required to provide customers on this system with an acceptable electric restoration time should a failure occur in the underground cable.

### **What you need to know about the Line Extension Policy:**

- The Line Extension Policy governs the costs of building line extensions.
- You will need a line extension to provide electricity to your development.
- Your cost for a line extension is our estimated cost to design and build electric facilities to serve your development less any credits to which you are entitled.
- Initial credits are based on the policies.
- More information on credits can be read further in this section. (See Policies, page 59)

# Steps to Follow to Provide Electric Service to Your Commercial/Industrial Subdivision

The following steps tell you how to obtain electric service for your subdivision. A book of this size cannot cover all situations. Please be sure to work with your new service representative to meet your needs. This book cannot take precedence over contracts that are developed for your project or the rules and regulations that govern line extensions. In most cases, you have the option to have telephone, cable TV and gas installed in the same trench as the PNM electric facilities. When joint trench utilities are planned for subdivisions, the customer will serve as the focal point for coordination of the project.

You may want to coordinate your need for construction power with your permanent line extension.

## **1. Plan for Electric Service**

**Consider the coordination of utility installation with your construction schedule.**

Just as you must work with construction plans for your development, we must develop plans for the power lines that will supply electricity to your site. Give consideration to how best to coordinate power line construction with your construction schedule.

- \* What type of electric service do you want to offer to your future tenants, single-phase, three-phase, or a combination of both?
- \* Three-phase commercial/industrial subdivisions designed to provide three-phase underground service are subject to certain restrictions for single-phase customers. Since these systems are designed to be operated as three-phase systems, the installation of single-phase transformers will not be permitted. Developers desiring the availability of single-phase service via single-phase transformers at certain properties may elect to have the system designed and constructed such that a separate cable is installed for single-phase service, in addition to the cables installed for the three-phase service.
- \* Where are the power lines and transformers going to be installed?
- \* Where and when would you like the construction power for your development?
- \* How will your grading, curb, and road installation affect installation of power facilities?
- \* How will other utilities affect installation of power facilities?



## 2. Submit Your Specifications to Us

[www.PNM.com/erequest](http://www.PNM.com/erequest)

**we can design the electric facilities to serve your development.**

All new service or upgrade requests require a Service Application be submitted to PNM. This is done through our on-line Electric Service eRequest system at [www.PNM.com/erequest](http://www.PNM.com/erequest). You'll be able to track your open requests and receive email notifications on the status of your request. Please submit your request as early as possible.

Electric service to a commercial/industrial subdivision can be very complex with many variables. Please discuss and coordinate your specifications with us as early as possible. In order for us to supply your development with electricity, we need to see your specifications, including the information in the following:

**We need your specifications, so that**

- \* site specification and filed plat in electronic format
- \* copy of warranty deed
- \* proposed public utility easement as required by the utilities
- \* existing easements of record on the property under development
- \* complete set of construction drawings
- \* streetlight locations as determined by the local authority
- \* any other specialty specifications

**Electric meter and transformer locations are sensitive issues during construction. Please let your business tenants know that there are limitations regarding electric meter and transformer locations.**

### **What you need to know about electric meter and transformer locations:**

- Ask your new service representative for meter and transformer locations.
- Transformers must be easily accessible for maintenance and operation.
- Refer to drawings MS-7-1.0, MS-7-2.0, DS-7-16.12 and DS-9-17.0 for required working and safety clearance around meters transformers and switchgear.
- Please pass this information on to your business tenants.

**Make sure your facilities are a safe distance from overhead lines.**

The National Electrical Safety Code (NESC) establishes clearances that must be maintained between power lines and buildings, signs, and other structures. **These clearances must be maintained regardless of easement boundaries.** When planning your facilities, please work with us to ensure that these required clearances are maintained.

**The Pre-design Conference is a key coordination opportunity.**

The Pre-design Conference includes other utilities, contractors, and any other concerned party to meet and discuss details of the project. Items that are discussed are not limited, and typically include our proposed electric system design, construction scheduling, utility location, joint use of easements by utilities, barricade requirements for trenches, dust control, and responsibility for opening and closing trenches. Decisions made during this conference will be incorporated into formal construction agreements.

**We will estimate the cost of the electrical facilities to serve you.**

After we receive your plans and typically after the pre-design conference, new service representative will contact you to discuss upfront costs related to your line extension and to assist you if required in your acquisition of necessary right-of-way to provide power to your development.

**We will comply with applicable environmental laws. The responsible protection of natural and cultural resources is a part of the cost of a line extension. This process can be lengthy depending on resources affected and land jurisdiction.**

Trenching

**See Trenching Policy, page 77.**

### **3. Develop Line Extension Agreement**

**The Line Extension Agreement is a contract for the cost of the line extension that will serve your development.**

You will need to discuss your service options with your new service representative. We will let you know your cost for the permanent line extension that will serve you. You must pay our estimated cost to build the line extension, less any credits for which you are eligible. The two types of credits available are explained in the following section.

**Policy summaries may be found in the chapter entitled “Policies”, page 59.**

The chapter on policies contains general summaries of policies that apply to all customer classes. Policies summarized in this chapter include:

- Line Clearances from Buildings, Signs, and Other Structures
- Access into PNM Equipment
- Customer Generation Systems
- Electric Line Extension Policy
- Metering Policy
- Trenching Policy

### **What you need to know about Lot Credits**

**When a line extension passes other unserved lots, the lot credit compensates the line extension customer for the service benefits to these lots.**

There are four types of lot credits available to compensate the customer for benefits provided to other properties by the line extension:

Lot credits apply only to lots properly filed and recorded in the County Clerk’s office. The customer will need to provide copies of this document to PNM in order to get this credit.

The lot credits include:

- \* **\$470** for each lot made ready for a service drop from either overhead or underground lines.
- \* **\$70** for each lot passed by the new underground backbone line, which will require padmount transformers and/or pedestals and/or secondary wire to provide future service.
- \* **\$340** for each lot passed by the new overhead backbone line, which will require pole-mounted transformers and/or secondary wire to provide future service.
- \* **\$130** for each lot made ready for a service drop by a new overhead transformer hung on an existing pole. This credit is in lieu of the \$470 credit mentioned above.

The total credit given will never exceed PNM’s bid or the Customer Built Option Cost, whichever is lower.

**If the customer believes the revenue from his project will exceed that identified on the revenue credit tables, he may sign a Revenue Credit Guarantee Agreement for meeting the higher revenue figure.**

## **What you need to know about Revenue Credits**

Up-front revenue credits will be determined by PNM.

In order to be eligible for revenue credits, final building plans must be provided to PNM.

**Any lot receiving a revenue credit is not eligible for a lot credit.**

Once defined, the revenue credit is firm. No revenue credit reconciliation will be made later.

A signed Revenue Credit Guarantee Agreement (RCGA) may be required for customers wishing to demonstrate revenue amounts exceeding those normally identified in the company's Revenue Estimation Table. The RCGA requires the customer to generate actual revenues, which meet or exceed the agreed-upon amount within the first 18 months of permanent electric service, or be billed for the difference. For further information on RCGA see your new service representative

### **4. Make Payment for Electric Facilities**

PNM can schedule construction for the electric facilities we design to serve you once we have received applicable payments and agreements.

### **5. Develop Your Commercial/Industrial Subdivision**

During this step, you will develop your site into a commercial/industrial subdivision, ready for occupation by businesses. We will construct the electrical system that will allow future businesses to receive electricity.

**This explains what you will do.**

All grading operations shall be completed before trenching. Please also schedule major landscape filling operations to follow line installation. Proper coordination of landscape operations with construction can reduce costs for all involved.

In general, all curb, gutter, main water and main sewer systems must be installed, and the grading must be within 6 inches of final grade before electric line installation can begin. All construction activities must be in compliance with the agreements reached in the pre-design meeting. It is very expensive to relocate facilities after construction. You must pay for this expense, if the relocation results from your requested changes or lack of compliance with PNM requirements.

**This explains what we will do.**

We will build facilities to provide electric service per your request to each lot within your development. Meters, transformers (if required), service connections for each business will be made in the future as described in the Single Businesses section, page 40.



# Policies

This section summarizes some of the major policies that govern how we conduct business.

These policies are:

- \* Line Clearances from Buildings, Signs, and Other Structures,
- \* Access to PNM Equipment,
- \* Customer Generation Systems,
- \* Rule 15; Electric Line Extension Policy,
- \* Rule 17; Metering Policy,
- \* Rule 18; Service Connections
- \* Trenching Policy,

All of these policies were developed with the goal of providing fair and consistent treatment to all our customers, including those needing line extensions and existing rate payers.

## **LINE CLEARANCES FROM BUILDINGS, SIGNS, AND OTHER STRUCTURES**

PNM installs, operates and maintains its overhead and underground lines in compliance with the National Electrical Safety Code (NESC). NESC clearance requirements or land use may change over time which can result in additional clearance needed for new construction. **Clearance requirements must be met whether or not your building or sign is in PNM's easement.** Clearances must be considered in the project planning stage to avoid additional cost. Please call us for assistance with clearances shown in DS-13-2.0 through DS-13-8.5. There may be a charge for any line work we must do to ensure compliance with the NESC.

## **ACCESS TO PNM EQUIPMENT**

PNM considers safety while working on the PNM system to be paramount. It is recognized that entry into PNM equipment, such as padmounted transformers and switchgear by third-party contractors may be necessary from time to time. Access into this equipment will be strictly controlled by PNM and shall be opened by authorized PNM personnel only.

A qualified contractor must make arrangements to gain access into PNM equipment for the purpose of installing conduit or pulling secondary cable. Whenever possible, the equipment will be de-energized prior to access. If the equipment cannot be de-energized, the contractor must make arrangements for an authorized PNM employee to be present as long as the equipment is open.

Any unauthorized access into PNM equipment will be considered trespass and will be prosecuted to the fullest extent of the law.

Please contact your local PNM office to gain permission to access PNM equipment.

## **CUSTOMER GENERATION SYSTEMS**

(Customer generation systems include synchronous machines, induction machines, power inverters, turbines, fuel cells, and photovoltaic systems.)

When a customer intends to install a generator, either for independent operation (Backup or Emergency) or for interconnected operation, they must make this known to their new service representative. PNM will review the final electrical drawings of all customer generation plans. The system shall be designed such that either (1) parallel operation of the generator with the utility system cannot occur or (2) the customer's generator and interconnection facilities comply with PNM's Interconnection and Safety Standards and requirements for interconnected parallel operation. The customer should contact PNM's New Service Delivery Department as soon as possible for specific guidance.

For generation systems that are intended for independent operation, a break-before-make type of transfer switch is required. PNM Engineering will review the proposed electrical plans which should include the following information: size of the generator (in KVA), voltage and phase, frequency, and disconnect details. PNM will inspect the installation for proper connection and break-before-make operation. After the installation has been approved by PNM Engineering, no modifications to the transfer switch connections will be permitted without PNM's approval.

Customers installing generators for the purpose of parallel operation will be required to comply with PNM's Interconnection and Safety Standards and Interconnection Requirements, as well as all applicable NMPRC Rules and local, state and federal codes and requirements. The customer will be required to complete a separate written application for the operation of a generator in parallel with the PNM system. In addition, the customer will be required to enter into an Interconnection Agreement with PNM. Interconnection Applications and additional information on parallel operation of generators can be obtained online at <https://www.pnm.com/solar-and-wind-energy> or by writing to:

Public Service Company of New Mexico  
RENEWABLE ENERGY  
414 Silver Ave. SW - MS1135  
Albuquerque, NM 87102

505-241-2491 or 505-241-2294



## **PREFACE TO ELECTRIC LINE EXTENSION POLICY**

**The customer's requesting new service is responsible for the cost of the line extension to provide that service.** However, the customer is entitled to lot and/or revenue credits which reduce the customer's cost obligation. The Electric Line Extension Policy defines the costs that customers are responsible for and the credits to which they are entitled. Payment of line extension cost is required prior to line extension construction

This policy applies to line extensions for service to new facilities and to the upgrade or modification of existing electrical systems to provide for increases in customer load requirements. Customer requested line relocations are not line extensions, and the costs of line relocations are not a part of line extension costs. All line relocation costs must be paid by the requester.

PNM can schedule construction for the electric facilities we design to serve you once we have received applicable payments, agreements, easements, and permits. Construction scheduling is a critical stage in the construction of your project. The advance planning outlined in the chapters of this guide will enable us to meet your needs.

## **Procedures for Customer-Built Electric Line Extensions**

Customers desiring new line extensions may have them constructed by a competent and qualified electrical contractor. For complete requirements, see Appendix 1 of Rule 15: Electric Line Extension Policy, which follows this section.

Important requirements of customer-built systems include:

- All line extensions must be designed by PNM.
- The customer must execute an Electric Line Extension Construction Agreement (Customer-Built) prior to construction of the customer-built system.
- The customer's contractor is not allowed to work on PNM's energized system. PNM line crews or its contractors will perform the connection and energizing of the customer-built system after all requirements are met.
- Materials used must be from PNM approved manufacturers in compliance with current PNM material specifications, as verified by a PNM inspector. Customers must obtain from the transformer supplier a PNM Certificate of Approval for distribution transformers being installed in PNM distribution systems. The transformer Certificate of Approval must be submitted to PNM prior to the transformer's field installation.
- All meters and associated metering transformers will be provided and installed by PNM.
- The customer's contractor must be properly qualified and licensed to construct electrical distribution systems.
- Facilities installed must be in compliance with PNM construction standards as verified by a PNM inspector.
- The customer must provide easements for electrical facilities in accordance with PNM's design and easement format.
- The customer is responsible for the cost of PNM's engineering and design, PNM inspection costs, and PNM costs of interconnecting and energizing the customer-built system.
- The Customer is liable for the direct and indirect consequences of any defects or failures of the electrical system for one year after the date of sale to PNM.
- The customer and PNM will sign an Electric Line Extension Sales Agreement (Customer-Built System) at closing. After purchase, PNM will energize and operate the electrical system.

Contact your new service representative for more information on Customer-Built Systems.

## **RULE 15: ELECTRIC LINE EXTENSION POLICY (EFFECTIVE 12-15-13)**

### **Introduction**

This Electric Line Extension Policy (LXP) outlines the procedures for installing field equipment necessary to provide new electric service to Public Service Company of New Mexico (PNM) residential and small commercial customers.

When connecting customers the Company, on behalf of its other customers and itself, will not make an investment in transmission and distribution equipment that is excessive or uneconomical.

This LXP does not apply to customers who will, in the Company's opinion, ultimately take electric service under PNM Rate Schedule Large Power, Industrial Power, Water and Sewage, or Large Service for Universities. In such situations, for these customers line extensions and service agreements will be established on an individual basis.

LXP customers may be charged for the preparation of a formal, binding cost estimate per Rate Schedule 16 for line extension construction or maintenance or related work to be performed at the customer's request, over and beyond the non-binding budgetary estimate routinely given at no cost. Each formal estimate is binding upon PNM for thirty (30) days. If the customer accepts the formal cost estimate and agrees to have PNM perform the work described in the work order estimate, the total cost of the estimate will be applied to reduce the customer's contribution to perform the job related work.

### **Definitions**

Line extension - A line extension consists of the installation of all field equipment necessary to provide for new electric service. Physical components of line extensions may include, but are not limited to, all primary wires, secondary wires, service wires, transformers, and meters, equipment supporting structures, trenches, switchgear, and duct bank systems. Line extension costs include all labor, materials, vehicles, and overheads required to design and construct the line extension, and to acquire easements, permits, and right-of-way necessary for its construction. Line extension costs also include the costs of changing existing facilities to provide the new electric service. Line relocations are not line extensions and shall be paid for by the customer.

Minimum Line Extension - The Minimum Line Extension is the line extension that would be designed solely to meet the needs of the customer requesting service, and is consistent with Company and industry design and safety standards. Sound engineering and economic considerations may require systems to be designed and built which exceed the needs of the Customer requesting service. The Company shall bear the portion of the costs of electrical system work done for the sake of area-wide system improvement. "Area-wide system improvement" shall be construed to mean any system capacity beyond what is specifically required for the particular customer in question.

### **Cost Responsibility: PNM Built**

The LXP customer shall be responsible for the costs associated with the Minimum Line Extension. The amount paid by the LXP customer will be the difference between PNM's Minimum Line Extension bid ("Bid") and an initial line extension credit, as determined by PNM. This amount must be paid, in full in accordance with the Company's line extension agreement by the LXP customer. The LXP

customer will be required to execute an Electric Line Extension Agreement (PNM Built), unless otherwise determined by the Company.

When a customer receives service under a residential tariff and upgrades their service capacity, the Company will determine necessary upgrades required of its distribution system. For upgrades where the service entrance equipment does not exceed 200 amps, the Company shall be responsible for the costs associated with the line extension. The Company will not connect upgraded services until the Company's equipment has been appropriately upgraded. Customers upgrading their service capacity above 200 amps will be required to pay for all PNM upgrade costs but will be eligible for an incremental revenue credit as determined by the Company.

PNM will review, on a regular basis, its procedures and assumptions for calculating the Bid to ensure that the Bid is as close as reasonable to the actual cost incurred by PNM. The amount paid by the LXP customer is non-refundable once construction activities have commenced.

## Cost Responsibility: Customer Built Option

The LXP customer may elect to have the line extension constructed by a qualified contractor, in lieu of PNM crews. In accordance with the requirements contained in the Customer Built System Requirements attached hereto as Appendix 1, PNM shall provide the engineering design, construction inspection and easement assurance at the LXP customer's expense. Thus, the LXP Customer will pay the actual cost of PNM's activities, in addition to the contractor's price ("Customer Built Option Cost"). Upon satisfactory completion of the project construction, PNM will assume ownership and responsibility for the new line extension, and the LXP customer will receive a line extension credit determined by PNM. The LXP customer will be required to execute an Electric Line Extension Construction Agreement (Customer Built) and Electric Line Extension Sales Agreement.

## Line Extension Credit

All LXP customers are eligible to receive line extension credit. Line extension credits are established to give consideration to the current and possible future electric customers served by the line extension. The credit will be employed to reduce the amount of the line extension cost actually paid by the LXP customer. The total credit given will not ever exceed PNM's Bid or the Customer Built Option Cost, whichever is lower.

The line extension credit may include consideration for a revenue credit and, if applicable, a credit for a platted lot:

### Revenue Credit:

The revenue credit relates to the customer's estimated annual electric usage and will be determined from the customer's final building design drawings. Customer site construction must be underway to qualify for this credit. The credit is determined from a table as set forth in the Company's Revenue Estimation Tables. There are separate tables for residential customers and for small commercial customers and these tables may be updated periodically. In situations where no standard revenue tables exist, revenue credits will be determined by the Company.

In situations where it is difficult to predict the future usage, or customer claim revenues that exceed the Revenue Estimation Tables, the LXP customer will be required to execute an Electric Line Extension Revenue Credit Guarantee Agreement ("RCGA"). LXP customers who execute a RCGA are required to generate annual revenues from the new line extension that meet or exceed the revenue credit granted.

## Lot Credit

If the line extension can serve more than one lot not presently receiving service, lot credit will be determined by the number of lots platted, filed and recorded with the County Clerk as defined in the table below. Lots eligible for a revenue credit will not be eligible for a lot credit.

In situations where it is difficult to predict when lots passed by the new line extension will be developed and require new service connections, the total credits received by the LXP customer may not exceed 66% of PNM's Bid. This would be applicable to lots that have been platted, filed and recorded for ten years or more without 10% of the total platted area developed.

<u>LOT CREDIT</u>	<u>LOT STATUS</u>
\$470/Lot	For each additional lot ready for a service connection from a new line extension.
\$70/Lot	For each additional lot passed by the new underground line extension, requiring a future transformer or pedestal, for a service connection.
\$340/Lot	For each additional lot passed by the new overhead line extension requiring a future transformer or secondary line for a service connection.
\$130/Lot	For each additional lot made ready for a service connection by the installation of an overhead transformer on an existing pole.

## Commencement of Residential Service Construction

In accordance with NMPRC Rule No. 410, within 30 days after a residential customer has complied with all the reasonable utility requirements, the Company shall provide to such customer a written estimate of the cost of the line extension. The Company shall complete construction of the line extension within 60 days after the residential customer signs the Company's line extension agreement, pays the required payment, and after the utility has secured all applicable permits, rights-of-way, materials and labor necessary for the line extension.

## Commencement of Commercial Service Construction

Construction of extensions for overhead and underground commercial service will commence within a reasonable time in accordance with the Company's construction schedule and after any required payment by the Customer for construction of the line extension is made.

## **RULE 15 APPENDIX 1: CUSTOMER BUILT SYSTEM REQUIREMENTS (12-15-13)**

Customers desiring new electric service lines and systems to be built to their premises may have them constructed by a competent and qualified electrical contractor. After construction and acceptance, such systems shall be sold to the Company for \$1.00 by the Customer. PNM then assumes ownership and maintenance responsibility of the system.

In recognition of the need to protect the public from electrical hazards, and the need for electrical systems which are useful and safely maintainable over a normal and customary service life, the following will govern the construction of customer-built electrical systems.

### **Design and Construction Specifications**

The Company will design the Minimum Line Extension required to serve the Customer, in accordance with the Company's standards and specifications. The Customer shall execute an Electric Line Extension Construction Agreement (Customer Built).

The Company will provide electrical system design drawings and associated bills of material to the Customer. The Customer shall pay the Company for applicable design costs.

### **Material Specifications**

The Company will specify all materials and equipment to be used in the electrical system including, but not limited to: wire, cable, conduit, transformers, poles, fixtures, switchgear, relays, capacitors, and insulators. The Customer shall be free to acquire said materials from any source, provided that all materials shall be from approved manufacturers and meet the specifications as promulgated by the Company that are in effect at the time the Company provides the Design and Construction Specifications to the Customer.

### **Quality Control and Assurance**

The Customer shall comply with Company specifications for materials, equipment, trenching, and construction standards. In order to assure compliance, the Company will select a Construction Inspector who will visit the construction site. The Inspector shall have the authority to accept, or reject, the work and materials of the Customer or contractor and shall certify such acceptance or rejection at the time of inspection. The sole function of the Inspector shall be to verify compliance with design, materials, equipment and installation specifications only. Customer shall be responsible for coordinating required inspections.

The Customer shall pay the Company for its reasonable costs incurred in the inspection of the electrical system.

The Company has no obligation to purchase an electrical system which is not accepted by the Company's Construction Inspector. In addition, the Company will not provide electric service to a system which is not accepted by the Company's Construction Inspector.

## Easements and Rights-Of-Way

The Customer shall provide to the Company easements and right-of-way in a Company-approved format which reflect the "as-built" configuration and location of the electric system.

The Company will assist the Customer in securing right-of-way necessary for the extension, if requested. The Customer shall pay the Company for such assistance.

The Customer shall pay the Company for its reasonable costs incurred to verify the easements and rights-of-way.

## Licensing Requirements and Compliance With Required Governmental Inspections

The Customer will hire only those contractors who are properly and currently qualified and licensed, in accordance with State and local law and regulation, to construct electrical distribution systems, including, but not limited to, EL-1 and EE98 certification.

Also, the Customer will comply with all applicable State and local construction inspection requirements.

PNM reserves the right to disapprove of any contractor selected by the Customer on the grounds that the contractor is not properly qualified or otherwise able to construct the line extension in accordance with the Company's construction standards.

## Meters

The purchase and installation of meters will be the sole responsibility of the Company. The Customer shall pay the Company its reasonable cost incurred to purchase and install meters.

## Purchase of System

After the electrical system has been constructed, and accepted by the Company's Construction Inspector, the Customer shall sell to the Company and the Company will buy the line extension for \$1.00. The Company and the Customer shall execute an Electric Line Extension Sales Agreement (Customer-Built) to transfer the property. This sale shall be free of any liens or encumbrances and the customer shall provide a properly executed release and/or waiver of lien from any contractor employed in this project. The Customer may also be required to execute an Electric Line Extension Revenue Credit Guarantee Agreement.

The Customer shall supply to the Company its certified cost incurred in constructing the electric system so that proper accounting of the electric system may be made by the Company.



## Liability for the Electrical System

Commencing with the date of sale of the electrical system to the Company, the Company will assume full and complete operating responsibility for the system. The Customer shall be liable for the direct and indirect consequences of any defects or failures of the electrical system constructed by the Customer for a period of one year, unless such defects or failures arise from the Company's design, specifications, or improper operation of the system.

## **RULE 17: METERING** **(EFFECTIVE 12-15-13)**

- A. All meters and related metering equipment shall be installed, owned, and maintained by the Company. For new load or line extensions, meter costs will be paid by the Customer in accordance with the current Line Extension Policy. The Customer must pay 100% of all meter costs resulting from customer-caused meter relocations.
- B. In the event a structure is built so that the meter location is inaccessible, or the meter becomes inaccessible to Company employees due to locked gates, Customer pets, or for any other reason under the control of the customer and not by the Company, the meter socket and/or service conduit or cable shall be moved to an accessible location at the expense of the Customer. In the alternative, the Company shall have the option of installing a remote meter reading device and billing the customer the actual installed cost of the device.
- C. The Company reserves the right to seal all meter entrance switches and all service entrance boxes regardless of ownership where the operation or tampering with such equipment may affect the registration of the meter or use of energy contrary to the provisions of these Rules and Regulations or the provisions of the applicable rate schedule.
- D. All meter sockets shall be of the outdoor type which shall be mounted at a height specified in the Company's Standards. In the case of overhead services, there shall be an unbroken conduit complete with wire or an approved cable run from the service entrance to the meter socket. The Customer shall furnish and install the cabinet (if required), meter socket and any necessary wiring from the Service Point to the meter socket per Company Standards. The meter socket shall be so located that it is entirely on the outside of the building and within ten (10) feet from the front of residential buildings or as approved by the Company. In the event a porch or other structure is built so that the meter location is inaccessible, the meter socket and/or service conduit shall be moved to an accessible location at the expense of the Customer. Whenever the construction of a building on an adjacent lot prevents proper access to any meter or the point of attachment of service conductor, the Customer shall move the meter socket and/or the service entrance conductor to a location which will be accessible to the Company's employees.
- E. The meter socket shall be so placed that the meter can be set and the seal installed easily. Should any plaster or abutments be installed after the socket is in place that would interfere with the setting of the meter and the seal, the Customer shall move the socket.
- F. Where more than one meter is required for a building, such as an apartment house, all of the meter sockets shall be grouped adjacent to each other and must be individually, permanently numbered by the Customer, and identified according to apartments or units. In remodeling where two separate houses are combined with an addition to form one building, the meter sockets shall be moved to a joint location. In all remodeling where the meter loop is changed or moved, or any change made in wiring, it will be necessary to install outdoor type meter sockets.
- G. All meters installed for commercial use shall be at a point designated by the Company. An outdoor location is preferred for all meters, provided the meters will not be subject to damage due to a hazardous location. No meter shall be installed in any location where it may be unnecessarily exposed to heat, cold, dampness, or other cause or in any unduly dirty or inaccessible location. There shall be an approved unbroken conduit complete with wire from the Service Point to the socket.

- H. All single-phase meters installed for Commercial use that do not require current transformers shall be socket type with the socket installed at a location approved by the Company. The meter sockets shall be mounted pursuant to Company Standards. The service equipment shall be installed as required by applicable codes.
- I. When meter installations require current transformers, the Customer shall furnish and install a metal cabinet per Company Standards to house the transformers. The cabinet shall be provided with a suitable means for mounting the transformers per Company Standards.
- J. In all installations requiring instrument transformers, whether single-phase or three-phase, the Customer shall provide the service entrance conductors.
- K. The Customer will install a metering and/or instrument cabinet in accordance with Company Standards whenever the Customer's load exceeds the capacity of the applicable self-contained meter.
- L. Metering and instrument cabinets shall not be used to house Customer-owned equipment, such as distribution panels or other equipment, nor used as a junction box for the distribution of circuits. All meter loops for single-phase meters that do not require current transformers shall be wired in accordance with the approved meter sequence; that is, (1) meter, (2) switch, (3) fuses.
- M. All meter loops for single-phase and three-phase, with or without meter instrument transformers, shall be wired in accordance with Company Standards. Whenever three-phase meters are installed on the outside of the building due to Company or other requirements, the Customer shall furnish and install an approved metallic, weatherproof cabinet to house the meters and metering transformers per Company requirements.
- N. All electricity sold by the Company shall be on a basis of meter measurement except, at the Company's sole discretion, for service or installations where the load is constant and the consumption may be readily computed.
- O. Upon request, the Company shall make a test of the meter serving the Customer. The Company may charge the Customer pursuant to Rate Schedule 16, for making such a test, such charge to be refunded to the Customer whenever the meter proves to be in excess of 2 percent in error.
  - 1. The Customer, or his/her representative, may be present when the meter is tested, if the Customer's request to be present is made at the time of his/her request for the meter test. The Company shall give the Customer reasonable advance notification as to the day, time, and place of test.
  - 2. A report of the results of the test shall be made to the Customer within a reasonable time after the completion of the test, and a record of the report, together with a complete record of each test, shall be kept on file at the office of the Company.

## **RULE 18: SERVICE CONNECTION** **(EFFECTIVE 12-15-13)**

- A. The Company will install one set of service wires up to the Service Point and necessary metering equipment. Equipment installed by the Company shall remain its property. For new load or line extensions, meter and service costs will be paid by the Customer in accordance with the current Line Extension Policy. The Customer must pay 100% of all meter and service costs resulting from Customer caused meter and service relocations. The Company will maintain its meter and service wires up to the Service Point. It is the Customer's responsibility to install and maintain all other wiring and equipment past the Service Point. This provision shall include the terminal support for the Company's service wires. In the case of overhead service, this shall be the point of attachment. For underground services (see Paragraph E for clarification), this shall be the first junction point available on the Customer's premises.
- B. The customer will install, own and maintain the service entrance equipment per Company requirements, which shall extend from the Service Point to the Customer's service equipment. All installations shall, at a minimum, comply with the National Electrical Code or appropriate state or municipal electrical codes, where these are in effect and have provisions in excess of the National Electrical Code.
- C. Further specifications are as follows:
  - 1. In all cases, the Customer or Electrical Contractor shall consult the Company for the proper location of the point of attachment and meter and for the proper elevation of point of attachment.
  - 2. Service drops to buildings cannot pass over any roofs unless provisions are made by the Customer for the wire to clear all buildings per the current National Electrical Safety Code edition in force. The point of attachment shall be placed so that there are no obstructions between it and the Company's pole from which the service will be run. The maximum length of service drop from pole to the attachment on the building shall depend upon the conductor size, but in no case shall exceed one hundred twenty-five (125) feet.
  - 3. The point of attachment shall be so adjusted as to provide the National Electrical Safety Code required ground clearance for the Company's overhead service wires and cables. The attachment provided by the Customer shall be of adequate strength to support the weight and tension of the service conductors. The Company shall not be responsible for any damage or injury caused by the failure of the Customer's structure or equipment at the point of attachment. The Customer must provide the repairs necessary for the Customer to safely reattach the service cables or wires.
  - 4. The service entrance weatherhead shall be so located that the distance between it and the point of attachment shall be one foot or less. The wire needed to make the connection between the service entrance weatherhead and the service drop shall be furnished by the Customer and for new services shall be left hanging from the weatherhead per Company requirements.
  - 5. Customer-owned secondary service entrance risers attached to Company-owned poles for underground service shall be placed as directed by the Company. The conduit shall be placed so as not to interfere with the attachments of communication facilities, nor shall any meters, switches, or attachments, other than the conduit, be placed on the pole except at the option of the Company.
  - 6. The service entrance shall be so located that it will not be necessary to install more than one set of attachments on the building being served to support the service wires for each class of service. The type of service to be provided will be at the discretion of the Company.

7. When permanent service poles are used as the terminal support for the Customer's service entrance equipment and the Company's service wires or cables, the pole shall meet the Company's construction standards. The type of permanent service pole used shall dictate the maximum length of the service drop. These standards shall be furnished by the Company upon request.
- D. When a Customer desires service to be delivered at a point or in a manner other than that specified by the Company, the customer will be responsible for resulting charges in accordance with the Company's NMPRC approved Rule 15 - Line Extension Policy.
  - E. Underground Services
    1. When service is supplied from a residential underground distribution system and the customer will be billed under the filed rate for Residential Service, the Company will provide and install the underground service to the meter base via the most direct route, as determined by the Company, up to a maximum of 100 feet. Where the Customer requires a meter to be located elsewhere than the location designated by the Company, where an indirect route must be taken by the service run, or where the service length exceeds 100 feet, the Customer will be required to make a nonrefundable contribution in Aid of Construction pursuant to the Company's NMPRC approved Rule 15 – Line Extension Policy.
    2. If the Customer desires an underground service from the Company's overhead distribution system, the necessary underground service wires extending from the point of service on the Customer's premises up to the point on the Company's pole from which connection is to be made shall be installed, maintained, owned, and paid for by the Customer. The meter in such cases will be located on the Customer's premises.
    3. Specifications of the service entrance shall be furnished by the Company upon request and said service entrance will be furnished by the Customer.
    4. Customer installations served from the downtown Albuquerque network shall include suitable protective devices conforming with Company Standards.
  - F. The Customer shall furnish and maintain a suitable location on their premises, satisfactory to the Company, for the meter and metering equipment as required by the Company's NMPRC approved Rule 17 - Metering.
  - G. When the Customer's combined requirements are in excess of 50 kVA, single-phase, or 100 kVA, single-and three-phase, either a padmounted transformer station or a transformer vault may be required, at the option of the Company. All expenses necessary for a padmounted station or a vault will be borne by the Customer. Construction specifications must be obtained from the Company before the job is started.
  - H. Specifications covering ground mounted pads and vaults are on file at the Company office and are available upon request to the Customer or Electrical Contractor. All wiring shall be installed in accordance with the Company's drawings and specifications on raceways, primary risers, and transformer pads and vaults.

- I. The Company reserves the right to refuse service whenever the Customer's installation does not conform to Company Standards or the terms and conditions contained herein, to the electric inspection department of municipality where required, to the laws of the State of New Mexico, to the rules and regulations of the National Fire Protection Association as set forth in the latest edition of the National Electrical Code, or to the clearance requirements of the National Electrical Safety Code as amended or abridged by authorized Boards in the State of New Mexico.
- J. The Company will install the necessary overhead service wires from the street, alley or road, or from the nearest pole of the Company so that the Company can span its wires directly to the point of connection on the Customer's building to the Customer's wires, and in such a manner that all wiring will be in plain view. For new load or line extensions, meter and service costs will be paid by the Customer in accordance with the current Line Extension Policy. The Customer must pay 100% of all meter and service costs resulting from Customer initiated meter and service relocations.
- K. The Company will determine what connections will be made and what wires will be installed by the Company for each distribution system.
- L. The Customer agrees, in accepting service, that no one except the employees of the Company shall be allowed to make an adjustment of any meter or other piece of apparatus which is the property of the Company.

## **TRENCHING POLICY**

### Trenching for Electric Facilities Only:

In those areas where we determine that standard trenching equipment cannot economically or practically excavate for an underground distribution system, the customer will either provide the necessary trenches for the entire distribution system or will pay PNM a non-refundable fee for all trenching costs incurred which exceeds the current cost of excavating by standard trenching equipment. When the customer provides the trench, the customer does not have to pay our estimated cost to excavate with standard trenching equipment.

### Trenching for Electric Facilities with Other Utilities:

PNM may choose to provide joint trenching and coordination for extensions to a single lot. For developments of two lots or greater, the customer will provide the trench. This will include trenching within the development and trenching leading up to the development. When the customer provides trenching for other utilities, i.e., gas, phone and/or cable, in a joint trench with PNM electric, the customer will be responsible for providing the necessary trenches and coordination with all utilities for the entire distribution system.

When the customer provides the joint trench, PNM will coordinate with the excavator for the timely installation of its electric facilities. PNM will also share its route with other utilities to facilitate their designs for the joint trench route. The following stipulations and guidelines apply when such a common trench is utilized:

- The installation shall be subject to conditions presented in this Guide.
- The installation shall be made in accordance with the provisions of all applicable codes including the National Electrical Safety Code.
- When a joint-use trench will include natural gas piping the excavator must meet the criteria established by the local gas distribution company. See your local gas representative for details.

When the Customer provides the trenching, the Customer may receive a trench credit against PNM's electric installation estimate(s) equal to the cost of the minimum trench required for the PNM facilities.

Customer provided trenching shall comply with OSHA and all applicable codes and local jurisdictional authority requirements. Refer to DS-10-8.0 pages 2-11 for trenching details. The Customer is responsible for all open trenches and must maintain the trenches for the entire duration that they are open. The Customer is also fully and solely responsible for guaranteeing and assuring that the trench is located within either: 1) dedicated easements to PNM, 2) dedicated public utility easements, or 3) dedicated road rights-of-way. Customer shall provide PNM with a survey verifying and certifying the location of the trench within such dedicated easements and/or road rights-of-way. Said survey shall be duly stamped and sealed by a licensed New Mexico surveyor. PNM will not energize facilities until the customer has provided PNM with said survey.





## **Customer-Owned Generating Systems: Interconnection and REC Purchase Programs**

This chapter focuses on the requirements for contractors and electricians involved in the design and installation of customer-owned generating systems up to 1 MW in size that will interconnect with PNM's electric grid. These include solar photovoltaic and solar thermal electric systems. We want to work with you and assist you so that these installations and interconnections work smoothly.

The requirements in this chapter are necessary for the continuing safety of our customers, contractors, electricians and PNM personnel. We provide this document to:

- Ensure compliance with the requirements of the New Mexico Public Regulation Commission
- Coordinate with the requirements of local government inspection and permitting agencies regarding enforcement of the National Electric Code (NEC), and the National Electric Safety Code (NESC).

Our process to provide you with electricity is governed by several policies that are approved and monitored by the New Mexico Public Regulation Commission. The complete text of these policies can be obtained from your new service representative. Most of these policies are included in summary form in the chapter of this document on "Policies", page 59. In this chapter, we provide you with the important information from these policies that affects the solar contractor and electrician.

All questions should be directed to 505-241-2589 or 505-241-2294.

## One Line Diagram Example Grid-Tied System

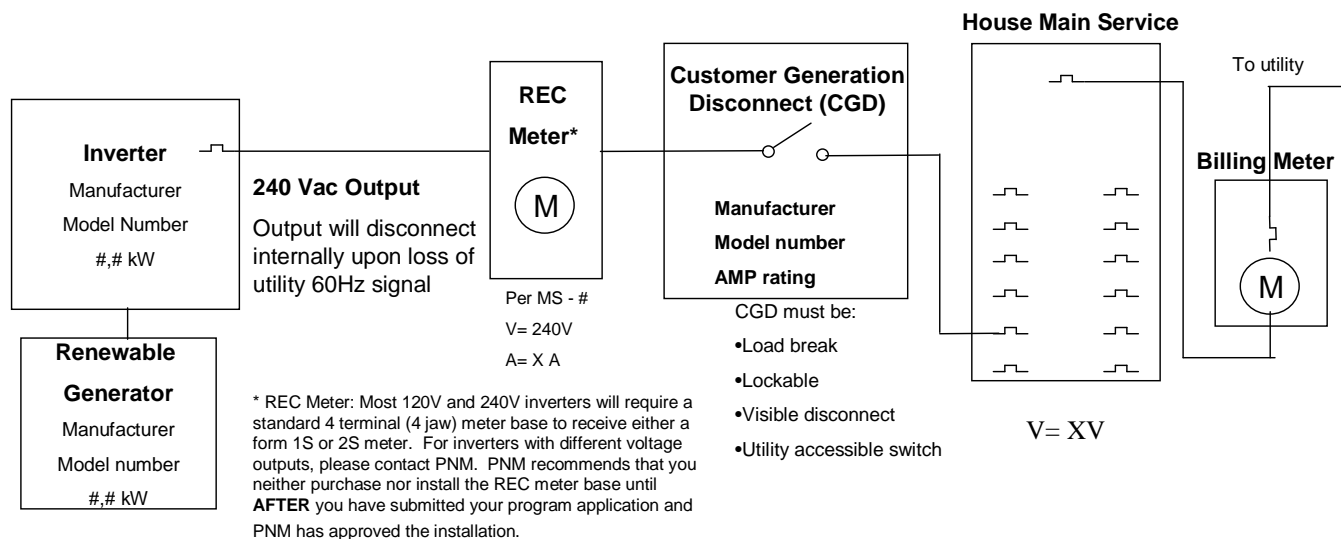

### Please include the following:

- Renewable generator (PV panels or solar thermal electric generator) manufacture, model number and total kW
- Inverter (must include manufacturer, model number, VAC rating and total combined nominal amps)
- Customer generation AC disconnect (must include manufacturer, model number and VAC rating and proper labeling) "load break, lockable, visible disconnect, utility accessible"
- REC meter (must include meter standard number and include metering voltage)
- Main service panel
- Billing meter
- Other (e.g. batteries, transfer switches, DC disconnect, etc.)

## One Line Diagram Example Line Side Tap

The purpose of this sample one-line diagram is show a utility line side tap. This occurs when the PV system is not wired into a back fed breaker within the house main service panel.

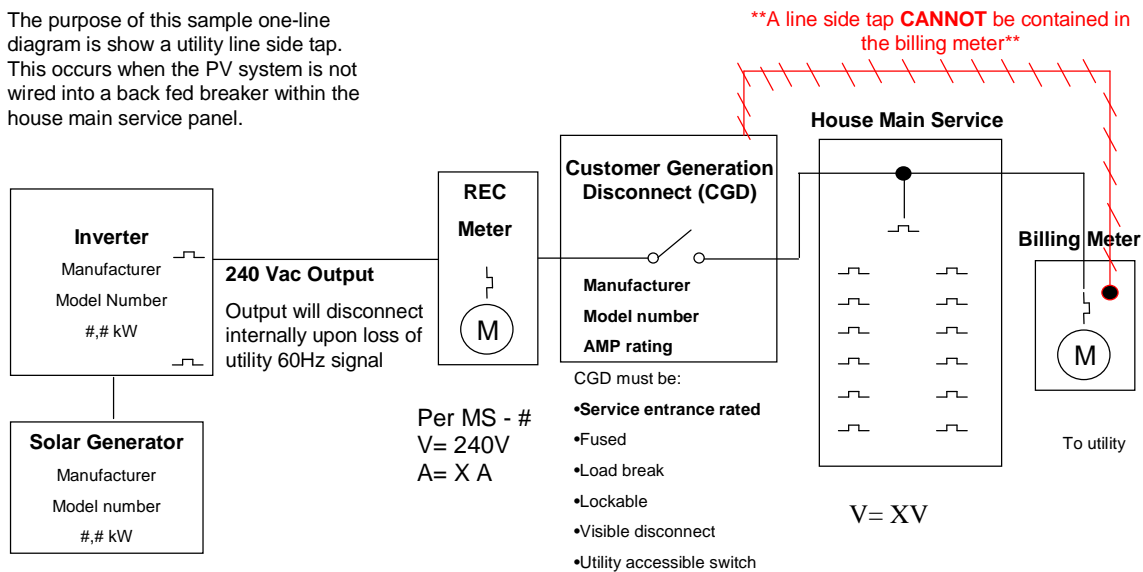

### Please include the following:

- Renewable generator ( PV panels or solar thermal electric generator) manufacture, model number and total kW
- Inverter (must include manufacturer, model number, VAC rating and total combined nominal amps)
- Customer generation AC disconnect (must include manufacturer, model number and VAC rating and proper labeling) "service entrance rated, load break, lockable, visible disconnect, utility accessible"
- REC meter (must include meter standard number and include metering voltage)
- Main service panel
- Billing meter
- Other (e.g. batteries, transfer switches, DC disconnect, etc.)

## One Line Diagram Example Battery Backup

The purpose of this sample one-line diagram is to show a PV system with battery backup. Please note, a battery backup system will reduce REC production.

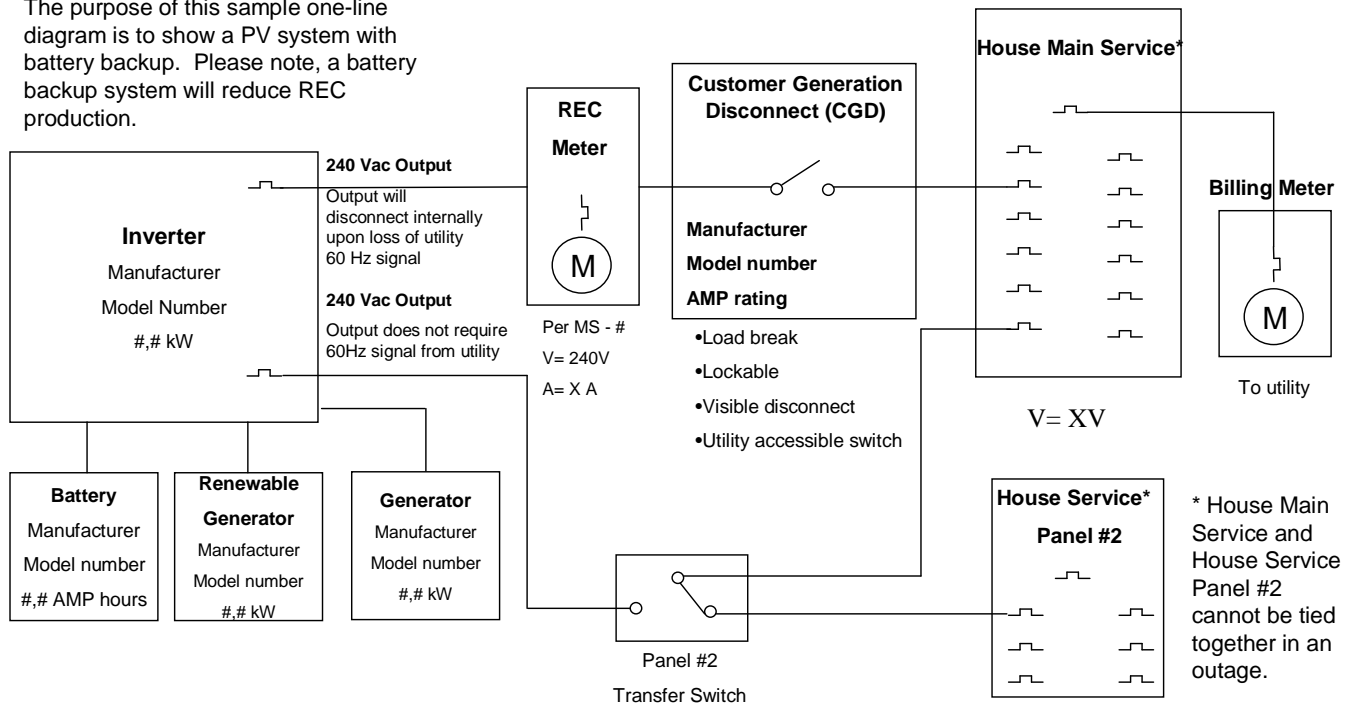

### Please include the following:

- Renewable generator (PV panels or solar thermal electric generator) manufacture, model number and total kW
- Inverter (must include manufacturer, model number, VAC rating and total combined nominal amps)
- Customer generation AC disconnect (must include manufacturer, model number and VAC rating and proper labeling) "load break, lockable, visible disconnect, utility accessible"
- REC meter (must include meter standard number and include metering voltage)
- Main service panel
- Billing meter
- Other (e.g. batteries, transfer switches, DC disconnect, etc.)

## Three-Line Diagram Example Grid-Tied System

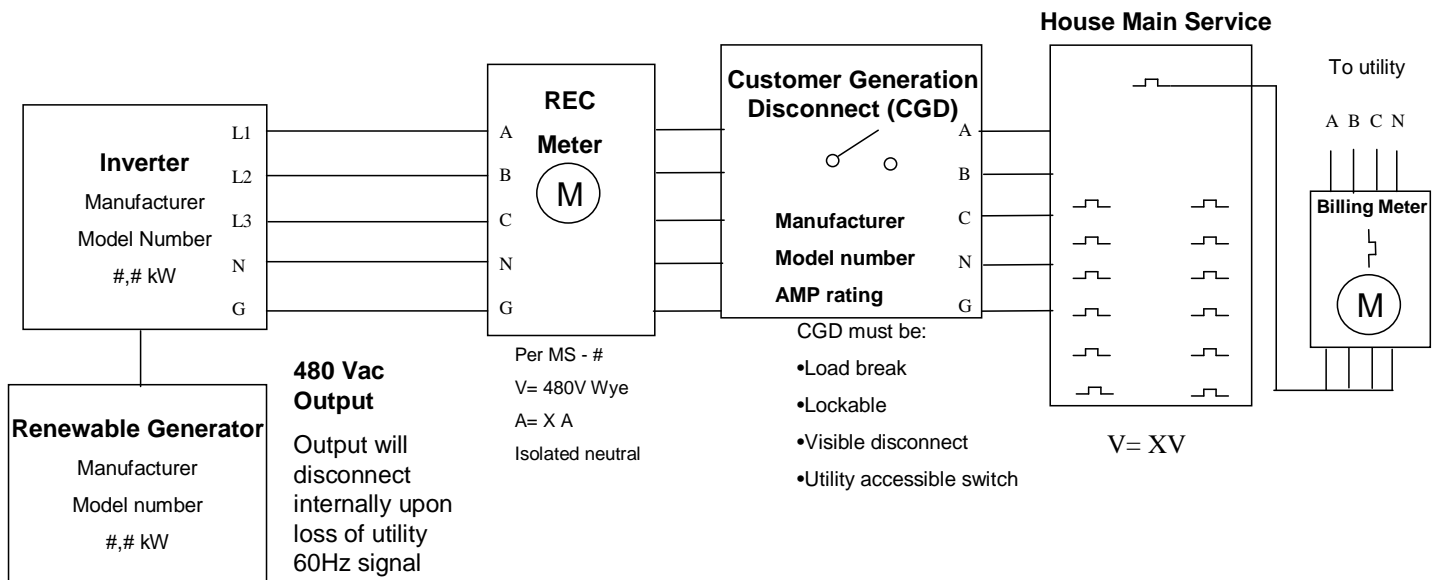

### Please include the following:

- Renewable generator ( PV panels or solar thermal electric generator) manufacture, model number and total kW
- Inverter (must include manufacturer, model number, VAC rating and total combined nominal amps)
- Max Inverter Fault Contribution
- Please describe the operational characteristics of the inverter(s) when subjected to a utility fault. This should include the three-phase, and phase-ground fault current contributions, and nominal voltage level, from the inverter(s), both in magnitude and duration over a period of up to 2 seconds.
- Transformer configurations and voltages
- (if customer owned equipment) transformer sizes and impedance values.
- (if customer owned equipment) protection equipment: size, type, manufacture.
- (if customer owned equipment) all equipment downstream of the common point of coupling must be included on drawings: i.e. transformers, switchgears, primary meters.
- Drawings must include all PNM equipment designated names and/or numbers. Drawings must reflect what is physically on site, apparatus numbers must be included (i.e. switchgears, transformers, meters, etc.)
- Drawings must be clear and concise and include all apparatus to PNM service. Must clearly include all conductors (include sizes) and terminating points to the common point of coupling
- Drawings must reference service entrance rated disconnect (if applicable)
- Customer generation AC disconnect (must include manufacturer, model number and VAC rating and proper labeling) "load break, lockable, visible disconnect, utility accessible"
- REC meter (must include meter standard number and include metering voltage) state isolated neutral (if applicable)
- Stamped drawings if greater than 50kW
- IDR meter is required if greater than or equal to 250kW
- If required CT or Primary Metering, customer is required to work with NSD for installation and payment
- Combined inverter(s) nominal output at REC meter. Include proper metering voltage. AIC rating of customer's service equipment.
- Combined inverter(s) nominal output at REC meter. Include proper metering voltage.

# SITE MAP

## (Figure 1)

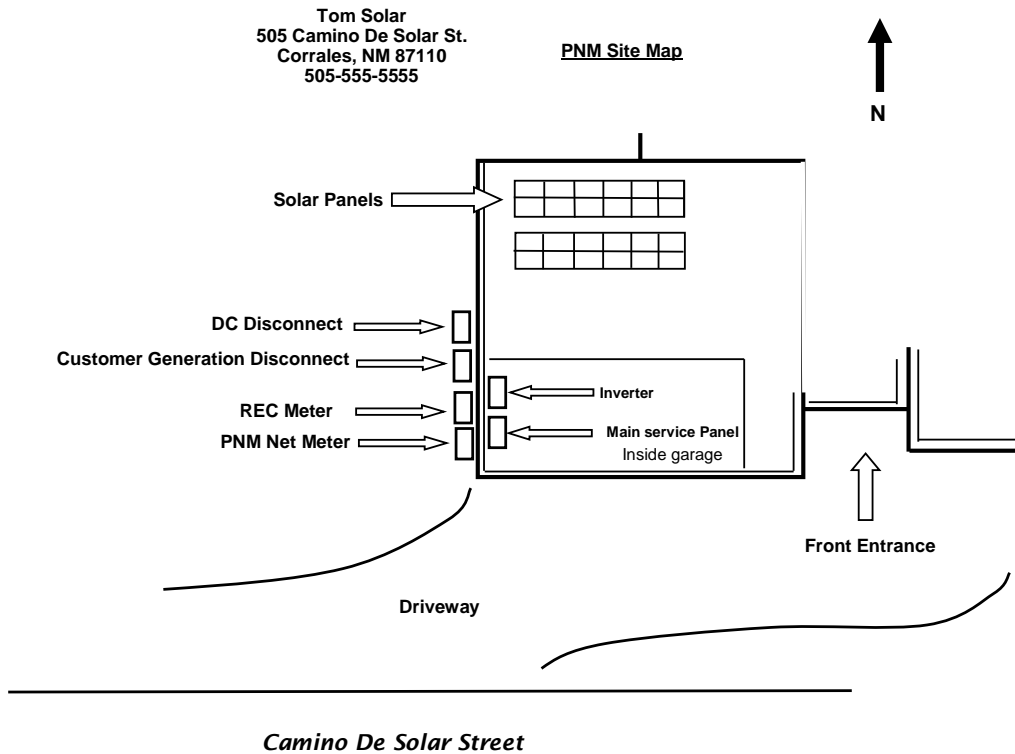

### Please include the following:

- Location of renewable generator ( PV panels or solar thermal electric generator) manufacture, model number and total kW
- Location of the inverter(s) (must include manufacturer, model number and kW rating)
- Location of the customer generation AC disconnect
- Location of the REC meter
- Location of main service panel
- Location of billing meter
- Direction indication
- Street name
- Customer name and address
- Other (e.g. batteries, transfer switches, DC disconnect, etc.)

**One-Line, Site Map and Placard Requirements**  
**(Figure 2)**

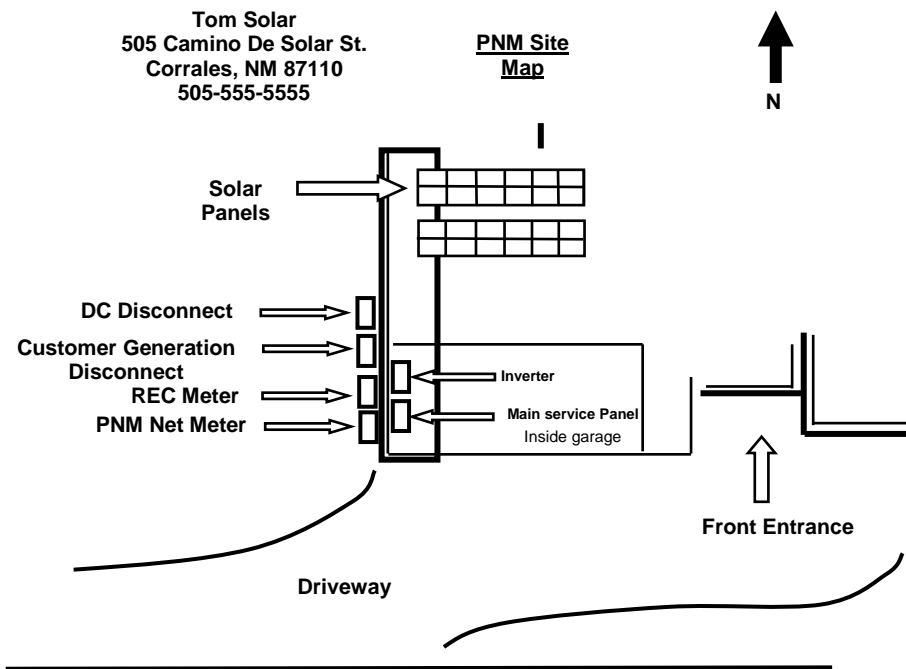

REC meter & Net Meter are grouped together and in plain line of sight.  
1-line diagram is placed at PNM Net Meter

The placard: "Utility Safety Disconnect use to Isolate from Customer Generation" is placed on the Customer Generation Disconnect

# One-Line, Site Map and Placard Requirements (Figure 3)

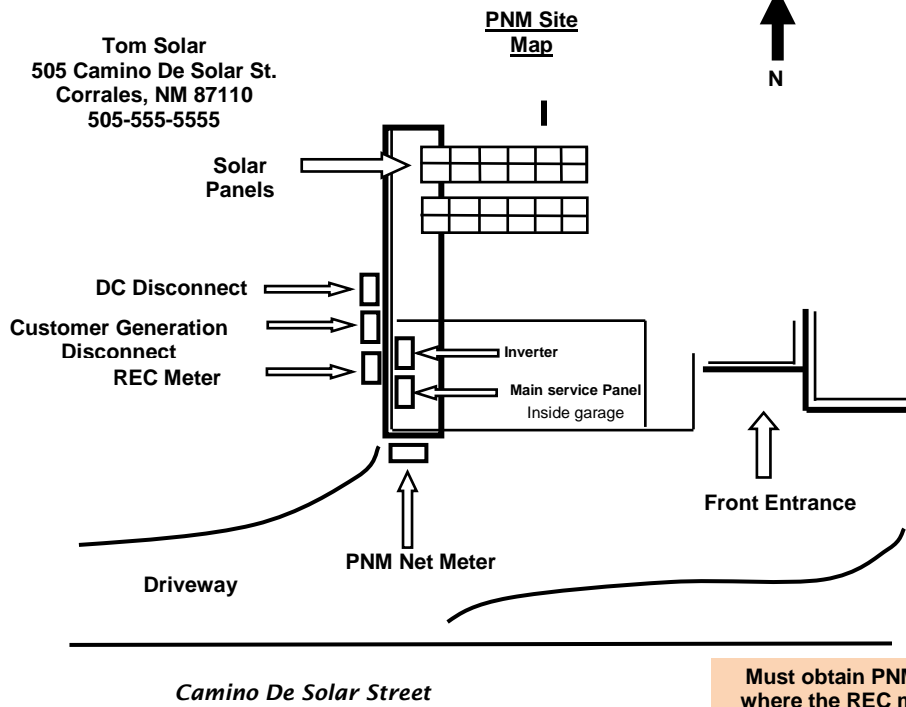

REC meter & Net Meter are not grouped together and not in plain line of sight  
Site Map is placed at the PNM Net Meter.  
1-line diagram is placed at the REC Meter.

The Placard: "Warning Customer-owned Generator Connected. See drawing for Disconnect Location" is placed at the PNM Net Meter

The placard: "Utility Safety Disconnect use to isolate from Customer Generation" is placed on the Customer Generation Disconnect

Must obtain PNM approval in cases where the REC meter and the Billing meter are not grouped together and not in plain line of site.



**One-Line, Site Map and Placard Requirements**  
**(Figure 4)**

Tom Solar  
 505 Camino De Solar St.  
 Corrales, NM 87110  
 505-555-5555

PNM Site  
Map



REC meter & Net Meter are not grouped together and not in plain line of sight. Site Map is placed at the PNM Net Meter. 1-line diagram is placed at the REC Meter.

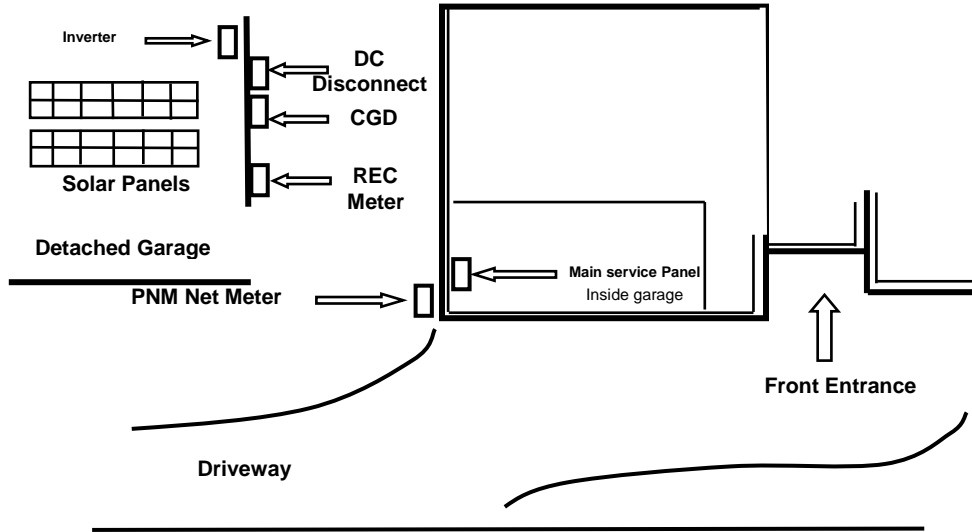

The Placard: "Warning Customer-owned Generator Connected. See drawing for Disconnect Location" is placed at the PNM Net Meter

The placard: "Utility Safety Disconnect use to isolate from Customer Generation" is placed on Customer Generation Disconnect

Must obtain PNM approval in cases where the REC meter and the Billing meter are not grouped together and not in plain line of sight.

**One-Line, Site Map and Placard Requirements**  
(Figure 5)

Tom Solar  
505 Camino De Solar St.  
Corrales, NM 87110  
505-555-5555

PNM Site  
Map

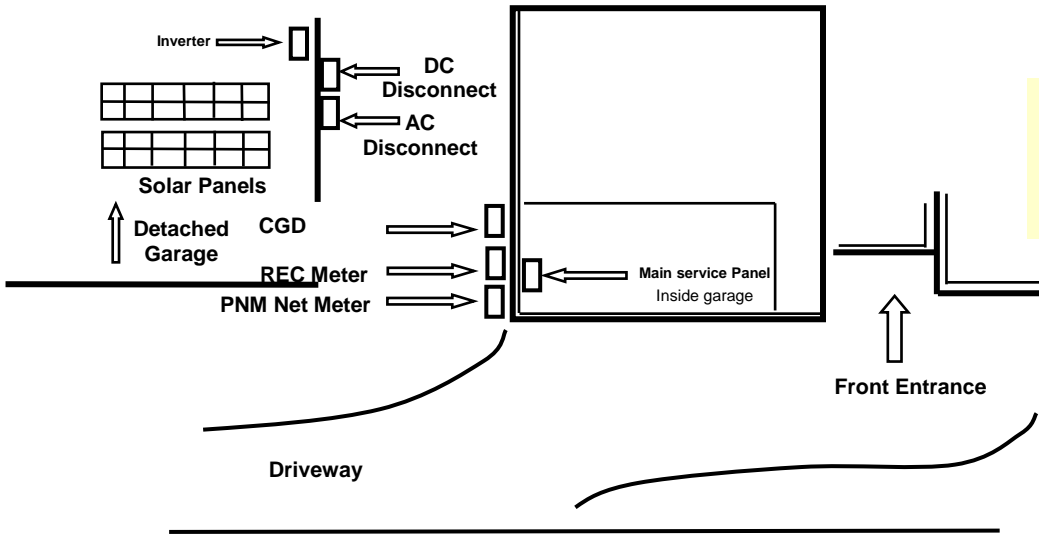

REC meter & Net Meter are grouped together and in plain line of sight. 1-line diagram is placed at the REC Meter.

The placard: "Utility Safety Disconnect use to isolate from Customer Generation" is placed on Customer Generation Disconnect.

Must obtain PNM approval in cases where the REC meter and the Billing meter are not grouped together and not in plain line of site.