

P1001 Unistrut Detail

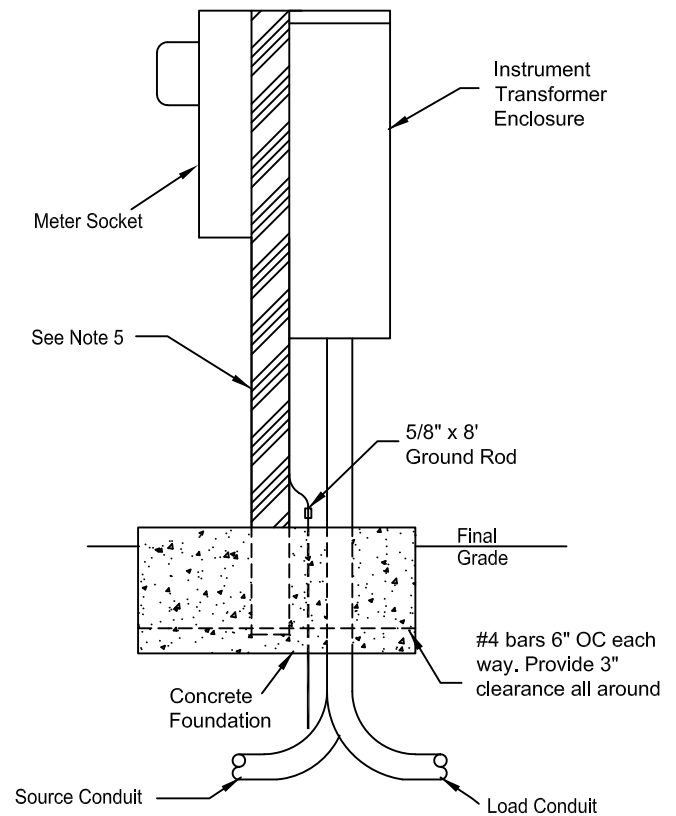
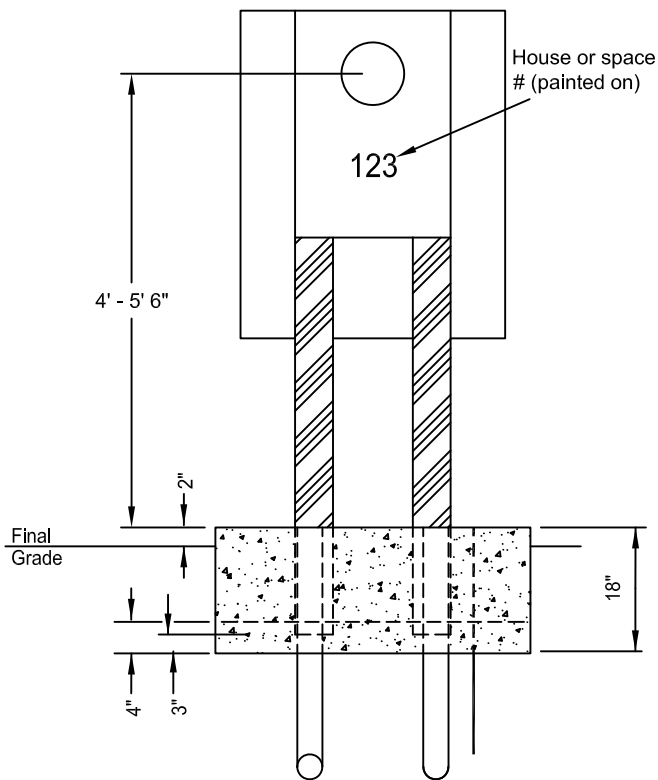

NOTES

- (1) Use 1" rigid nipple between instrument transformer enclosure and meter enclosure for secondary wiring.
- (2) Enclosures shall be securely attached to support members either bolted directly or mounted to metal channel or unistrut cross members.
- (3) Rigid galvanized, Schedule 80 PVC or IMC conduit shall be used for source and load conduits. No junction box or cable trough is permitted ahead of the metering enclosure.
- (4) Guard posts will be required in traffic areas as specified.
- (5) Acceptable support members are as follows:
 - 3" x 3" $\frac{1}{2}$ " Angle
 - 3" x 4.1 lbs/ft Channel
 - 2" x 2" $\frac{3}{16}$ " Box Steel
 - 2 $\frac{1}{2}$ " Standard Pipe
 - P1001 Unistrut (See Steel Detail)

REFERENCES

- (1) See DM-4-11.0 Maximum Available Fault Currents
- (2) See DS-7-16.10 Guard Post
- (3) See MS-2-7.0 Three-Phase Thirteen-Terminal CT Meter Socket
- (4) See MS-3-3.0 Recording Meter Instrument Transformer Enclosure

For ease of checking service without interruption, PNM will no longer allow ring meter sockets as of 12/01/2013.