

A

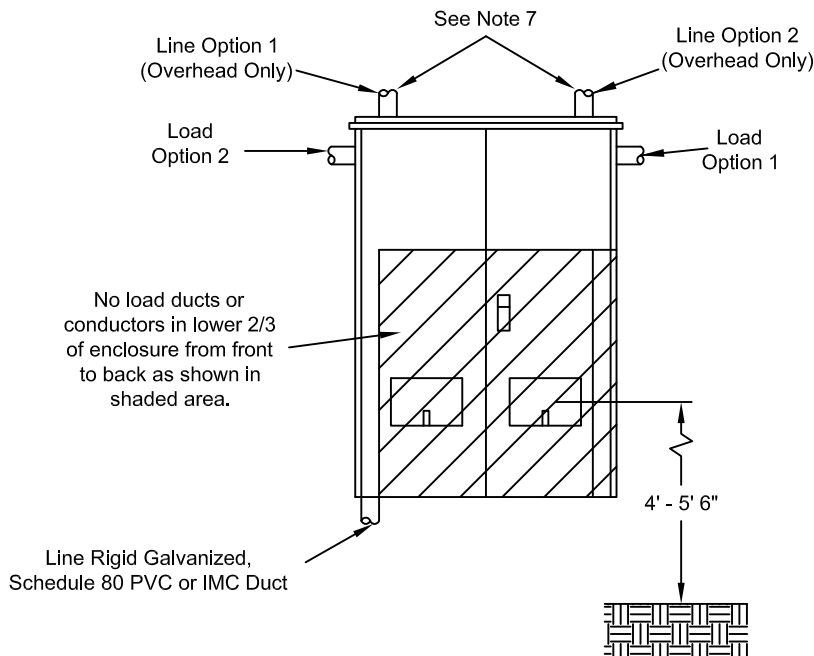

B

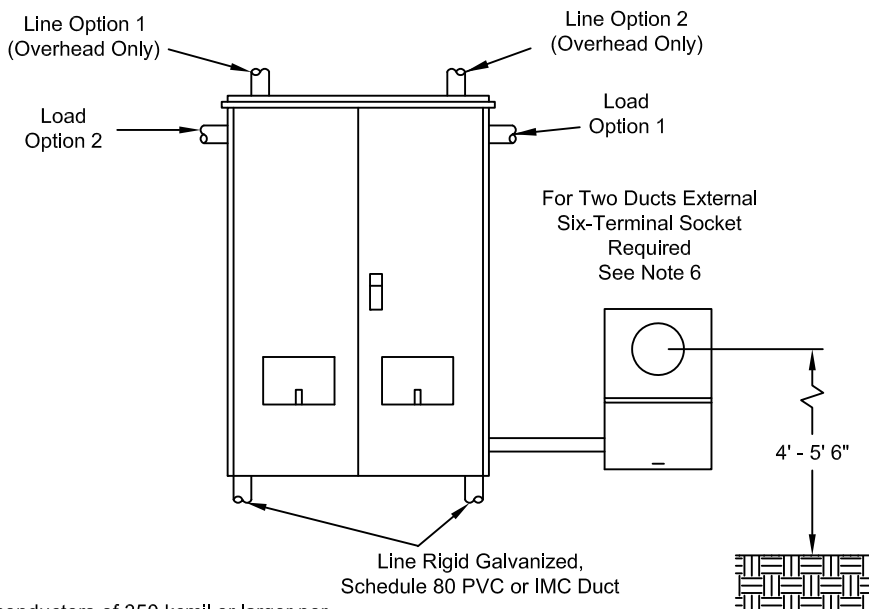

NOTES

- (1) Enclosure must be used when parallel conductors of 350 kcmil or larger per phase are installed. (600A main disconnect or larger)
- (2) Must have 3/4" plywood backing inside enclosure installed by contractor.
- (3) Use only one of two load options.
- (4) Enclosure shall be securely mounted to building.
- (5) Line and load options shall be on different quarter section.
- (6) If the number of runs or duct size meets that allowed by Table A, use MS-2-6.5.
- (7) When using load out top of CT can, a J-Box or LB must be used within 2' of existing can. The same will be for single-phase ITT when coming in underground and exiting out top side with load conductors.
- (8) 1-2-3 to be identified in RED, Neutral in WHITE. For Delta services the third (wild) leg in ORANGE. Leave wire rolled up in CT can and ensure the wire is long enough to reach Main Disconnect Panel (MDP)

REFERENCES

- (1) See MS-2-6.5 Single-Phase Six-Terminal CT Meter Socket
- (2) See MS-3-2.0 Double-Window Three-Phase Instrument Transformer and Meter Enclosure

Table A

Allowed Number of Ducts	Maximum Conductors Size
2	750 kcmil Overhead ONLY
3	500 kcmil
4	Not Allowed
Maximum Three Conductors Per Duct	

All conduits or nipples exiting a CT enclosure will be the same size as the entrance conduits without exception.

Over 320A 240V Single-Phase Meter

MS-3-7.0